

Si 830



*Engineering
GREAT Solutions*

**High Flow Safety Relief Valves
designed acc. to API Standard 526
manufactured to ASME VIII and PED**

Contents

03 Features, applications, approvals and standards

04 General information

07 Type code

08 Coefficients of discharge

12 Material code

14 Trim codes

18 Sizes, pressure ranges and dimensions

18 D orifice

20 E orifice

22 F orifice

24 G orifice

26 H orifice

28 J orifice

30 K orifice

32 L orifice

34 M orifice

36 N orifice

38 P orifice

40 Q orifice

42 R orifice

44 T orifice

46 Material code orifice V and W

48 V orifice

50 W orifice

52 Air capacities USCS units

53 Air Capacities SI units

54 Saturated steam capacities USCS units

55 Saturated steam capacities SI units

56 Water capacities USCS units

57 Water capacities SI units

58 Heating jacket (option .18)

59 Design options

Si 8301

Features

The IMI Bopp & Reuther API safety valve:

- > Full nozzle design
- > Orifice sizes D – T are in full compliance to API Standard 526
- > Additional orifice sizes V and W for very large flow application
- > Capacities certified by the National Board of Boiler and Pressure Vessel Inspectors
- > Large range of materials and design options meeting all specifications
- > One-trim design for gas, vapour and liquids
- > Long-life cycle bellows design
- > Positive lift stop at full capacity
- > Optimized disc bearing for high seat tightness
- > Nozzle ring always set to lowest position because valve designed to operate optimum without ring adjustment
- > Easy maintenance by one-part spindle, simplified disc retention clip, rugged guide design

Inlet sizes

NPS 1 to NPS 8 acc. API 526 and larger sizes NPS 10 as well as NPS 12

Inlet pressure rating

Class 150 to Class 2500

Set pressures

0.5 bar g up to 414 bar g
7 psig up to 6000 psig

Temperature range

- 268 °C to + 538 °C
- 450 °F to + 1000 °F

Overpressure

Vapours / gases 10%
Liquid 10%
(ASME type classification: Safety Relief Valve)

Blow down

Vapours / gases 7%
Liquids 20%

Allowable built-up back pressure

15% of the set pressure

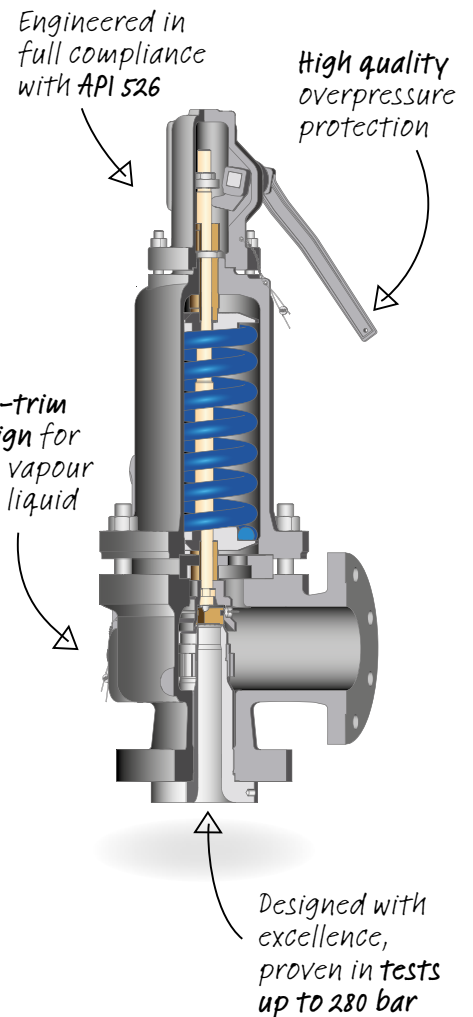

Applications

- > Vapours, gases, steam, liquids and two-phase applications
- > Applications in accordance with API Standard 521 and API Standard 520
- > Technical design in accordance with API Standard 526
- > Closed pressure systems, back pressures, high pressures
- > Oil/gas – onshore and offshore
- > Petrochemicals, refineries and tank farm
- > Chemical industry
- > Boiler and steam systems to ASME Sec. VIII
- > Nuclear facilities to ASME Sec. III

Approvals and standards

ASME Certification

- ASME Boiler & Pressure Vessel Code Section VIII
- ASME Boiler & Pressure Vessel Code Section III

EC type examination

- Pressure Equipment Directive 97 / 23 /EC
- DIN EN ISO 4126-1
- AD 2000-Merkblatt A2
- VdTÜV Merkblatt "Sicherheitsventil 100"

VdTÜV type approval acc. to TÜV.SV.10-1006.d₀.D/G/F.α_w.p

IMI Bopp & Reuther will not renew the existing VdTÜV type approvals. The requirements by VdTÜV and applicable standards are completely considered by the EC type examination.

The design, manufacture, testing and labelling meet the requirements of ASME B16.5, ASME VIII, API 526 and DIN EN ISO 4126-7, DIN EN 12266-1/-2 (insofar as applicable to safety valves) DIN EN 1092 parts I and II Flanges, AD 2000-Merkblatt A4, AD 2000-Merkblatt HPO, technical rules for steam boiler TRD 108, TRD 110, TRD 421.

General information

Safety valves have the function of preventing inadmissible overpressure in pipe systems, pressure vessels and boilers, in order to avoid danger to people, plant and the environment. They are set to a higher pressure than the operating pressure of the system to be protected.

Safety valves ...

- ... open once the set pressure is reached.
- ... steady discharge the required mass flow.
- ... close after the pressure has dropped.

The Si 8 series is part of the IMI Bopp & Reuther **High Flow** application category and the required capacity is usually the most important criteria for selection. The standard valve is of the direct spring loaded type, a safety valve where the opening force generated by the fluid pressure under the disc is counteractive to the mechanical load of a spring.

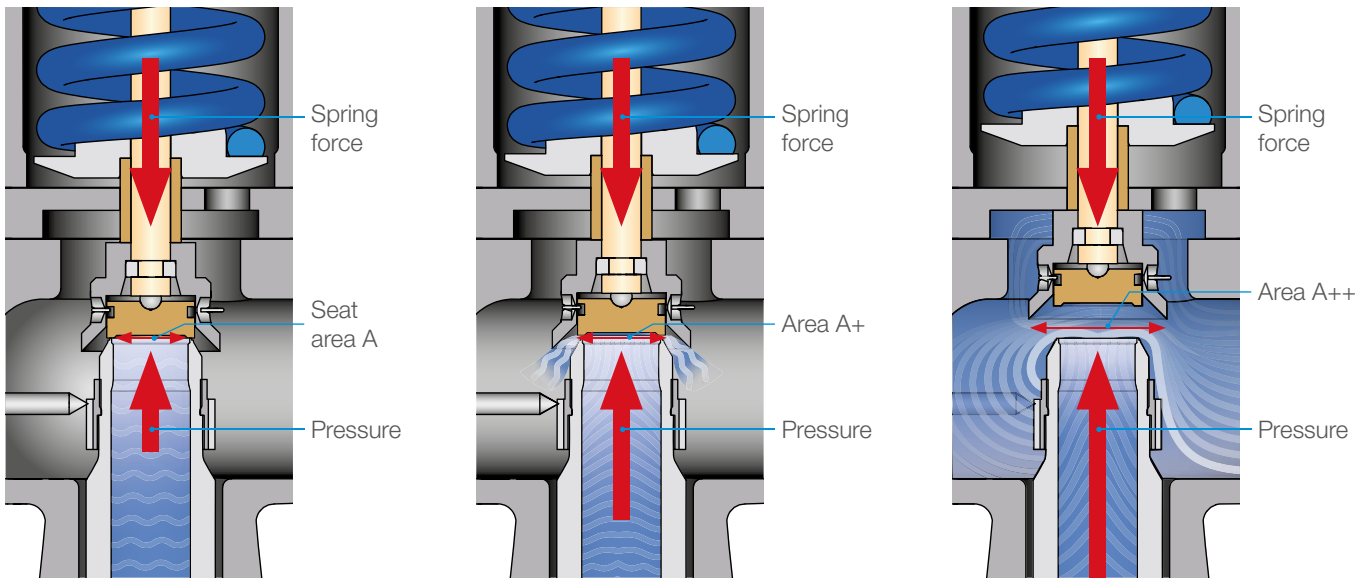

During normal operation the spring force applies a higher load to the disc than the opening force generated by the pressure and the disc closes the valve nozzle seat. In case the system pressure increases the pressure force tends to balance the spring force.

In gas or vapour service the disc typically lifts slightly before it will rapidly open ("simmering"). An initial audible sound is caused by the fluid passing the seat. Pressure now builds up past the seat and acts on larger areas of the disc and disc holder A+. This flow area is optimum designed for all IMI Bopp & Reuther safety valves and no ring adjustment is required.

Once the pressure has built-up further past the seat and is fully acting on the disc holder flow area A++, the additional forces overcome the spring force and the safety valve will rapidly open to full lift.

Allowing the disc to reclose the system pressure has drop to a level that the spring force can overcome the force of the additional disc holder flow area A++. The difference between opening and closing pressure is the blowdown.

Lift-pressure-Graph (typical)

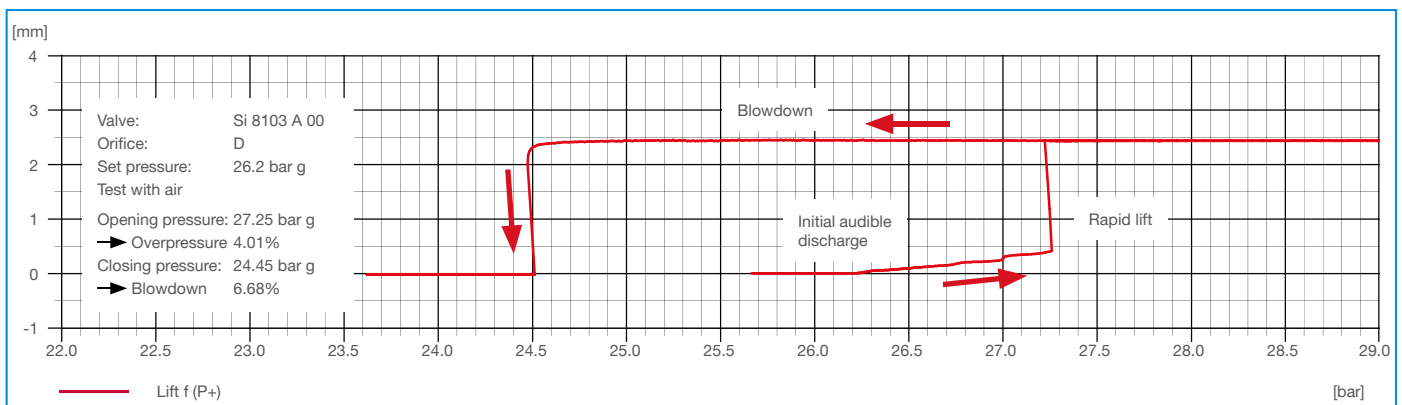

General information

What is an API safety valve?

API is the acronym for “American Petroleum Institute” – the largest US trade association for the oil and gas industry with its headquarters in Washington, D.C. One important aspect of its work is the establishment of technical standards for the oil and gas industry such as:

> **API Standard 520 – Sizing, Selection, and Installation of Pressure-relieving Devices**

Covers the sizing and selection of pressure-relief devices to protect unfired pressure vessels against overpressure in refineries and chemical plants.

> **API Standard 526 – Flanged Steel Pressure-relief Valves**

Purchase specification and basic requirements for direct spring-loaded pressure-relief valves and pilot-operated pressure-relief valves.

The IMI Bopp & Reuther valve series Si 8 is designed in accordance with the requirements set forth in API Standard 526 including:

- > Orifice designation and area
- > Valve size and pressure rating
- > Materials
- > Pressure-temperature limits
- > Center-to-face dimensions

and the Si 8 series meets the capacities for gas, vapours and liquids calculated on the basis of orifice sizes given in API Standard 526 and effective coefficients of discharge detailed in API Standard 520 as a minimum.

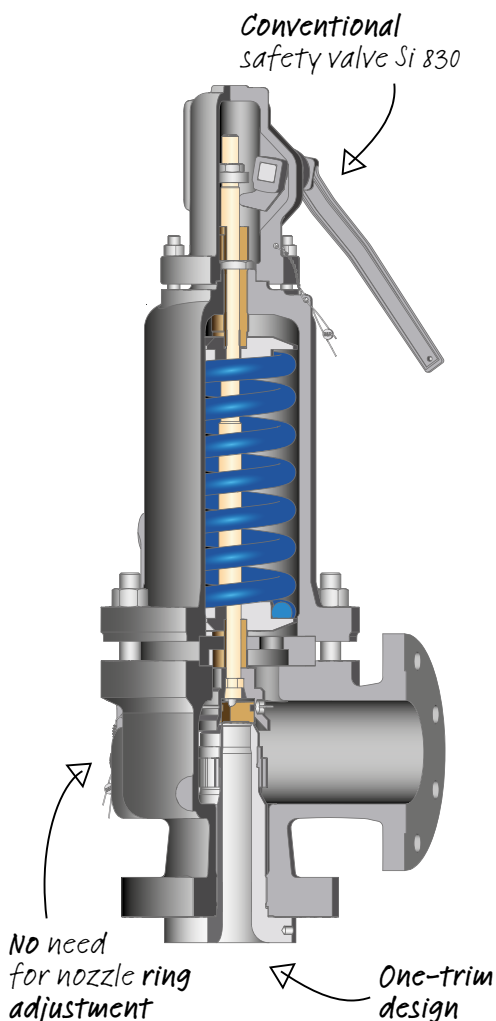

Conventional safety valve Si 830

The IMI Bopp & Reuther series Si 830 are most commonly used in process plants. The closed spring bonnet traps the process fluid in the valve and prevents a release to the environment. The straightforward construction and reliable guidance of the stainless steel inside parts ensure free and repeated discharge cycles.

As specified in API 520 and ASME Sec. VIII the safety valves shall have an adjusting ring to adjust the blowdown in order to meet the specified limits. However IMI Bopp & Reuther design philosophy builds on optimized flow geometry and suitable spring selection ensuring the required functional characteristic of the safety valve. The Si 8 series nozzle ring does not require adjustment and is always screwed to the lowest position. The plant benefit is added operation reliability and ease of maintenance.

The Si 8 series is a One-trim design for gas, vapour and liquids. Flow forces generated by the fluid pressure are optimized regardless media allowing utilization of suitable springs to comply with functional requirements. The one-trim design makes the Si 8 series especially suitable where installation see gas and liquid relief cases or on 2-phase flow applications.

Conventional safety valves are usually selected where a short outlet pipe leads to the atmosphere, where the fluid is safely discharged into low pressure systems and where the fluid is non-critical.

The conventional safety valve limit for built-up back pressure is 15% of the set pressure. In case of constant super-imposed back pressure, a conventional safety valve is set to the differential pressure ($p - p_v$).

General information

Safety valve with bellows Si 840

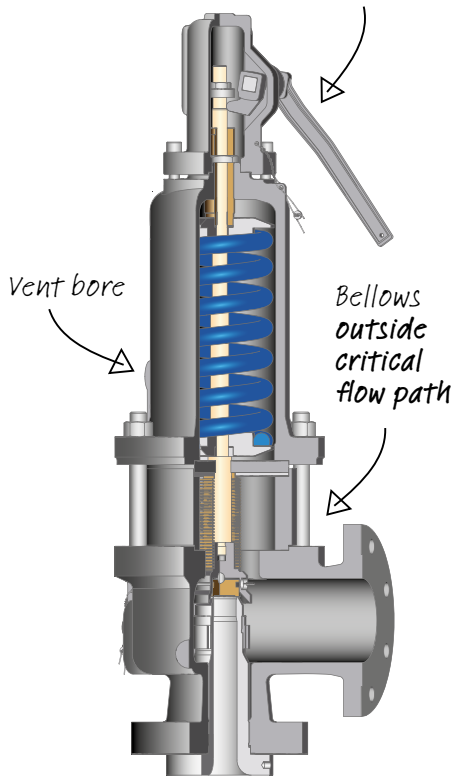

Safety valve with bellows Si 840

The Si 84 and Si 85 series are equipped with a bellows between the body and bonnet. The following conditions require the selection of bellows:

- > Excessive built-up back pressure or variable superimposed back pressure. The bellows has a balancing effect on the back pressure.
- > When the fluid is highly viscous or contains solid particles that could enter the guiding areas. The bellows protects the guides.
- > When the fluid could have a corrosive effect on the inner parts. The bellows separates the bonnet chamber from the flow.
- > In case of media with a very high temperature. The bellows shields the spring against overheating.

During relief the fluid passes the seat area and flows to the body outlet. The bellows is embedded in a bonnet spacer and outside the critical flow path. Thereby the impact of pressure pulsation, vibration or media itself is reduced significantly and the bellows operation life time increased.

Bellows safety valves have a vent bore in the bonnet and which needs to be open or connected to atmospheric tank to ensure bellows and safety valve function. The vent bore can be used for bellows integrity test.

Vent size	Orifice size
G $\frac{1}{4}$	D to J
G $\frac{3}{8}$	K to T

Retrofit kits are available at IMI Bopp & Reuther to convert conventional design Si 83 or Si 81 valves to bellows design Si 84 or Si 85.

Safety valve with open bonnet Si 81

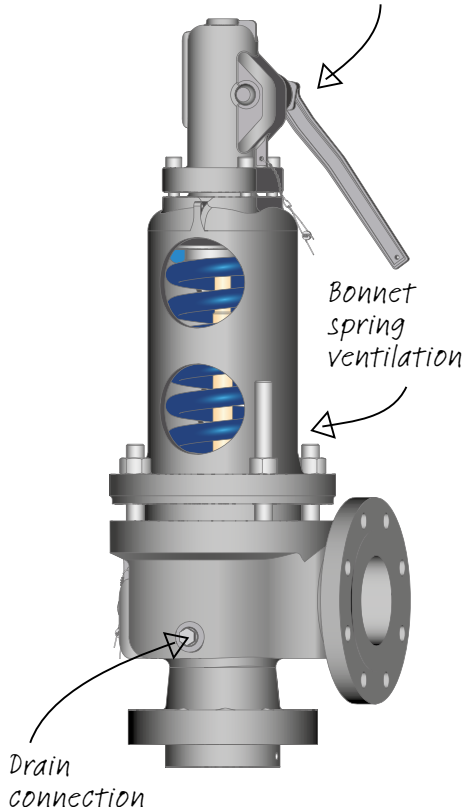

Safety valve with open bonnet Si 810

In the safety valve series Si 81 the spring bonnet has an open design. The resulting ventilation of the bonnet chamber permits a standard steel spring to be used in fluid temperatures up to 400 °C. In higher temperatures, a bonnet spacer between the body and bonnet can provide the spring with further protection from overheating (design option .15), or a bellows can be additionally integrated as the best possible measure (type Si 85).

Safety valves for steam application under ASME Sec. VIII require a lifting lever and hence cap type A shall be selected.

Si 81 safety valves have a drain connection to prevent condensate from lodging in the body discharge side. Drain lines shall lead to a safe place of discharge.

Drain size	Valve inlet size
G $\frac{1}{4}$	NPS 1 to NPS 2
G $\frac{3}{8}$	NPS 3 to NPS 4
G $\frac{1}{2}$	NPS 6
G $\frac{3}{4}$	NPS 8 and above

Steam applications under ASME Sec. VIII are limited to 2900 psi / 200 bar. For supercritical pressures or flow requirements exceeding the capacities of series Si 8 the IMI Bopp & Reuther series Si 910 offers a more extensive range of sizes, pressures and materials. Series Si 910 is fully approved to ASME Sec. I and ASME Sec. VIII. Please see catalogue Si 910 for more information.

Si 830

Type code

Type code				Order example
1	Series	Si 8	API Safety Relief Valve	Si 8
2	Design	1	Conventional, open bonnet	4
		3	Conventional, closed bonnet	
		4	Bellows, closed bonnet	
		5	Bellows, open bonnet	
3	Characteristic	0	High capacity "High Flow"	0
4	Pressure class ¹⁾	1	Class 150 (PN 16)	3
		2 ²⁾	Class 300 (PN 25)	
		3	Class 300 (PN 40)	
		4	Class 600, class 300 at T orifice (PN 100)	
		5	Class 900 (PN 160)	
		6	Class 1500 (PN 250)	
		7	Class 2500 (PN 400)	
5	Cap	G	Gastight cap	G
		GB	Gastight cap with test gag	
		A	Packed lifting lever	
		AB	Packed lifting lever with test gag	
		AK ³⁾	Pneumatic actuator	
6	Material code ⁴⁾	00	SA-216 Gr. WCB	00N1
		01	SA-217 Gr. WC6	
		04	SA-351 Gr. CF8M	
		22	SA-352 Gr. LCB	
7	Options ⁵⁾	.09	Locking sleeve (government ring)	
		.11t	Soft seal disc PTFE	
		.14a ⁶⁾	Lift indicator, proximity switch in the cap	
		.14b ⁶⁾	Lift indicator, proximity switch in auxiliary housing	
		.15	Bonnet insulation spacer	
		.17	Balancing piston	
		.18	Heating jacket	
		.25	Block body design	
		.28	Oil and grease free	
		.32	Purge connection	
		.36	Body drain	
		.59	Stellited disc	
		.60	Stellited nozzle	

¹⁾ PN ratings acc. DIN/EN are for reference only and availability not detailed in this catalogue. In case DIN/EN flanges are required, please use the IMI Bopp & Reuther sizing software Si-Tech 4 or consult the factory.

²⁾ Pressure class 2 valves are set pressure limited in accordance to API Standard 526 for low pressure applications where a class 300 inlet flange is preferred over a class 150 flange.

³⁾ The design option pneumatic actuator is selectable for application acc. to European Standard PED or where no code marking is required. Acc. to ASME Sec. VIII Safety Relief Valves shall be of direct spring loaded type and pneumatic actuator is not permitted.

⁴⁾ The standard materials of the material codes can be changed by selecting trim codes. Please see pages 14 – 17 for detailed information.

⁵⁾ More design options are available in compliance to European Standard PED, but not approved under ASME Sec. VIII, e.g. lift restriction (.35), vibration damper (.38) and weight loading (.57). Please see IMI Bopp & Reuther sizing software Si-Tech 4 with calculation standard ISO 4126 or consult factory.

⁶⁾ In combination with design option .14a/b the valve is not gastight anymore. Bellows design needs to be selected in case the valve shall be gastight.

Type ▶	Si 8403 G 00N1	
Please state ▶	Set pressure	320 psig
	Fluid temp.	60° F
	Fluid and State	Natural gas gas
	Inlet	NPS 2, class 300
	Outlet	NPS 3, class 150
	Orifice	H
	Code stamp	ASME VIII (UV) NACE MR0175 (trim code N1)

Si 830

Certified coefficient of discharge acc. ASME Section VIII Div. 1

Media	Inlet size	Orifice designator	Set pressure range	Cert. Coefficient of discharge K
Gas, vapour and steam ¹⁾	NPS 1 to NPS 1½	D	15-6000 psi 1.03-414 bar	0.53 ²⁾
	NPS 1 to NPS 12	E-W	Limits given in subsequent tables	0.86
Liquid	NPS 1 to NPS 1½	D	15-6000 psi 1.03-414 bar	0.41 ²⁾
	NPS 1 to NPS 12	E-W	Limits given in subsequent tables	0.675

¹⁾ The maximum set pressure for steam is 2900 psi / 200 bar or the range limit for each orifice, whichever is lower.

²⁾ The coefficient of discharge for orifice D are calculated on the basis of the certified slope value 2.20 SCFM/PSIA for gas and the certified flow factor 3.51 GPM/SQ.RT.PSID for liquid.

The IMI Bopp & Reuther safety relief valve series Si 8 is designed, manufactured, tested and marked in accordance to ASME Boiler and Pressure Vessel Code, Section VIII. Capacities for gas, vapour, steam and liquids are certified by The National Board of Boiler and Pressure Vessel Inspectors. The basics of size and capacity calculation are described in the ASME Code Section VIII Division 1 Section UG-131 and in Appendix 11. The section UG-131 is also used to determine the

certified capacity for air, saturated steam and water. The formulas for calculating the capacity for other gases or vapors are given in Annex 11.

The standard effective orifice areas according to API 526 are valid only for the size calculation using the equations and effective discharge $K_d = 0.975$ for gas / vapor or $K_d = 0.65$ for liquids from API Standard 520. Irrespective of the later valve selection a preliminary sizing calculation can be done by use of the

standard effective orifice and effective coefficient of discharge. Once a safety valve is selected, the final calculation must be verified with the certified characteristics of this valve.

The orifice sizes V and W are not specified in API 526, the valve sizing calculation with the effective discharge coefficients K_d from API 520 is possible with the effective flow cross-sections provided below.

Flow area

Orifice designator	Certified flow area A (use with certified coefficient of discharge K)		API 526 Standard effective orifice area (use with effective coefficient of discharge as per API 520, $K_d = 0,975$ for gas/vapour and $K_d = 0,65$ for liquid)	
	[in ²]	[mm ²]	[in ²]	[mm ²]
D	0.225	145	0.110	71
E	0.225	145	0.196	126
F	0.352	227	0.307	198
G	0.578	373	0.503	324
H	0.901	581	0.785	506
J	1.474	951	1.287	830
K	2.107	1359	1.836	1185
L	3.266	2107	2.853	1840
M	4.123	2660	3.600	2322
N	4.971	3207	4.340	2800
P	7.312	4717	6.380	4116
Q	12.665	8171	11.050	7129
R	18.328	11824	16.000	10322
T	29.778	19212	26.000	16774
V ¹⁾	50.911	32846	44.910	28968
W ¹⁾	73.070	47144	64.450	41583

¹⁾ Orifices V and W are not specified in API Standard 526 and are a definition by IMI Bopp & Reuther.

Si 830

Sample size calculation for a safety valve in gas service acc. to API 520

Fluid

Natural gas

Temperature T

80 °C = 353,15 K

Isentropic exponent k

1.27

Molar mass M

19.0 kg / kmol

Compressibility factor Z

1.0

Set pressure

1500 kPa g

Relieving pressure P₁ at 10% accumulation

(1500 x 1.1)+101=1751 kPa a

Back pressure P₂

600 kPa g (superimposed var.)

Required capacity W

24000 kg/hr

The following SI unit equation is used for sizing the required area for critical gas flow:

$$A = \frac{W}{C K_d P_1 K_b K_c} \sqrt{\frac{T Z}{M}}$$

With no upstream rupture disc being used $K_c = 1$.

For Si 8 series the back pressure correction factor K_b can be read from below curve. With $P_2/P_1 = 0.4$ the factor K_b is 0.965.

The value of coefficient C can be obtained from API 520, figure 32 or table 8, with $k = 1.27$ the coefficient $C = 0.0261$ for SI units.

$$A_{\text{required}} = \frac{24000}{0.0261 \times 0.86 \times 1751 \times 0.965 \times 1} \sqrt{\frac{353.15 \times 1}{19}} = 2728 \text{ mm}^2$$

The certified area 3207 mm² is greater than the required area and orifice N a suitable selection. Due to the superimposed back pressure a balanced bellows design is required and the safety valve Si 8403 G 00, NPS 4 Cl. 300 x NPS 6 Cl. 150, orifice N is suitable for the application.

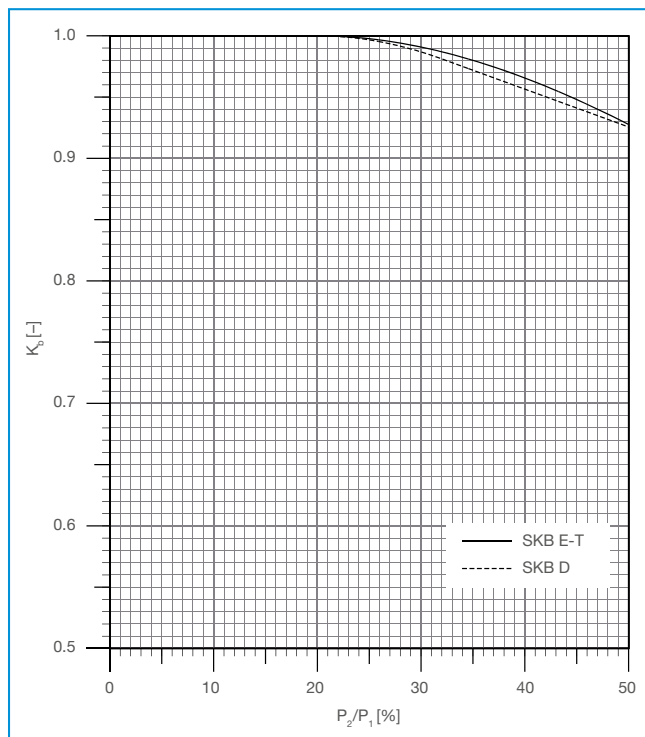

This curve shows the capacity correction factor K_b due to backpressure for gas and vapour applicable to series Si 8 valves and is based on flow test results. The factor considers the capacity decreasing impact of back pressure during relief and shall be used for orifice sizing and capacity calculation acc. to API 520 und ASME VIII. The shown factor K_b is applicable also for relieving pressures below 50 psi (3.45 bar) and for conventional design Si 83 safety relief valves.

P_1 = Relieving pressure, absolute (Set pressure + allowable overpressure + atmospheric pressure)

P_2 = Back pressure, absolute

Back pressure correctur factor K_b for gas and vapours

Si 830

Coefficient of discharge acc. VdTÜV and PED

Fluid group	Inlet size	Flow diameter	$h/d_0 \geq$	$p_b/p_0 \leq$	α_w
Vapours / gases (D / G)	NPS 1 to NPS 1½	13.6 mm (D)	0.162	0.2	0.53
	NPS 1 bis NPS 12	13.6 mm to 245 mm (E to W)	0.35		0.86
Liquids (F)	NPS 1 to NPS 1½	13.6 mm (D)	0.162	0.2	0.366
	NPS 1 bis NPS 12	13.6 mm to 245 mm (E to W)	0.35		0.643

The flow areas and orifice designator detailed on previous page for API/ASME are as well applicable for certification and calculation acc. to DIN EN ISO 4126 and AD200-Merkblatt A2.

The coefficient of discharge for gases / vapours in a pressure ratio of $p_b / p_0 > 0.2$ is shown in the diagram below.

The capacity of the selected safety valves can be adjusted to the required capacity by reducing the lift, thus reducing undesirable extra performance. The required ratio h/d_0 is shown in the diagram below, and the reduced lift calculated with $h_{(\text{reduced})} = d_0 \times (h/d_0)$.

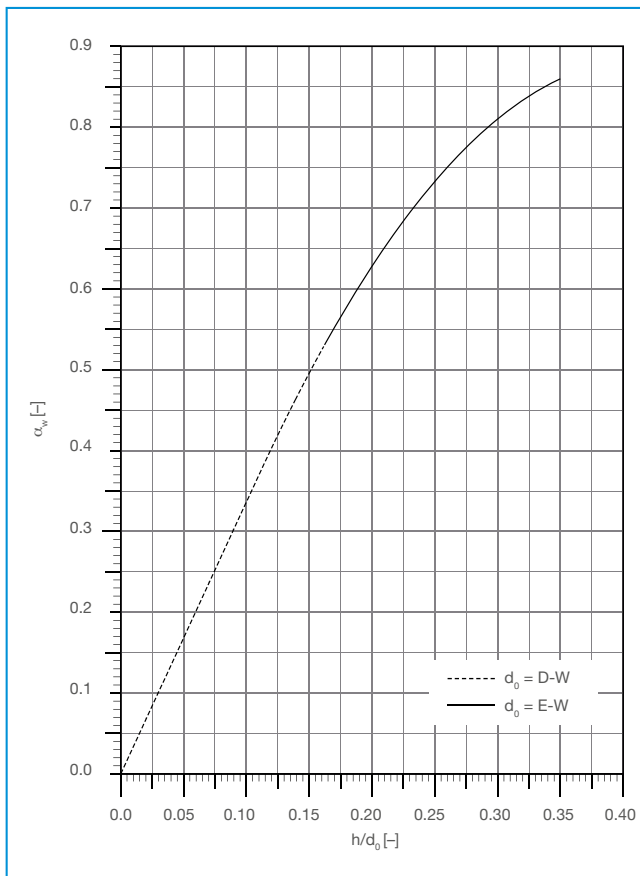

Si 830 coefficient of discharge α_w depending on h/d_0 for gases and vapours

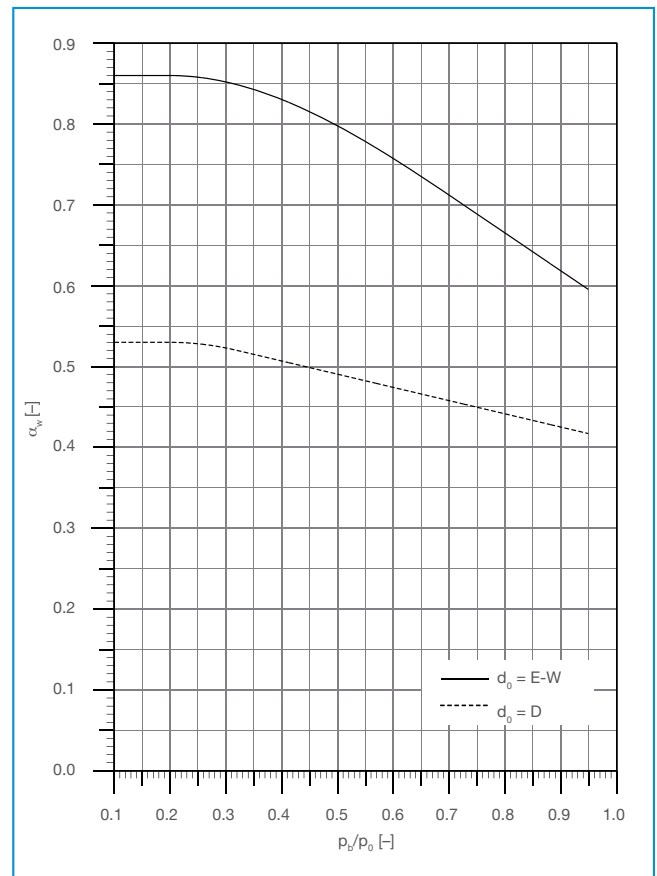

Si 830 coefficient of discharge α_w depending on p_b/p_0 for gases and vapours

Si 830

Sample size calculation for a safety valve in gas service acc. to DIN EN ISO 4126-7

Fluid

Natural gas

Temperature T_0
 $80\text{ }^\circ\text{C} = 353.15\text{ K}$
Isentropic exponent k

1.27

Molar mass M

19.0 kg/kmol

Compressibility factor Z

1.0

Set pressure

15.0 bar g

Relieving pressure p_0 at 10% accumulation
 $(15.0 \times 1.1) + 1.01 = 17.51\text{ bar a}$
Back pressure p_b

6.0 bar g (superimposed var.)

Required capacity q_m

24000 kg/hr

As the condition for critical flow

$$p_b \leq \left(\frac{2}{k+1}\right)^{\frac{k}{k-1}} p_0 \text{ is met in the example, the following applies: } A = \frac{q_m}{p_0 C K_{dr} \sqrt{\frac{M}{Z T_0}}}$$

 The value of coefficient C can be obtained from DIN EN ISO 4126-7, figure 11 or table 3, with $k = 1.27$ the coefficient $C = 2.613$.

 Using the pressure ratio $p_b/p_0 = 0,4$ the certified coefficient of discharge can be read as $K_{dr} = 0.83$ in diagram "Si 830 coefficient of discharge α_w depending on p_b/p_0 for gases and vapours".

$$A = \frac{24000}{17.71 \times 2.613 \times 0.83 \sqrt{\frac{19}{1.0 \times 353.1}}} = 2725\text{ mm}^2$$

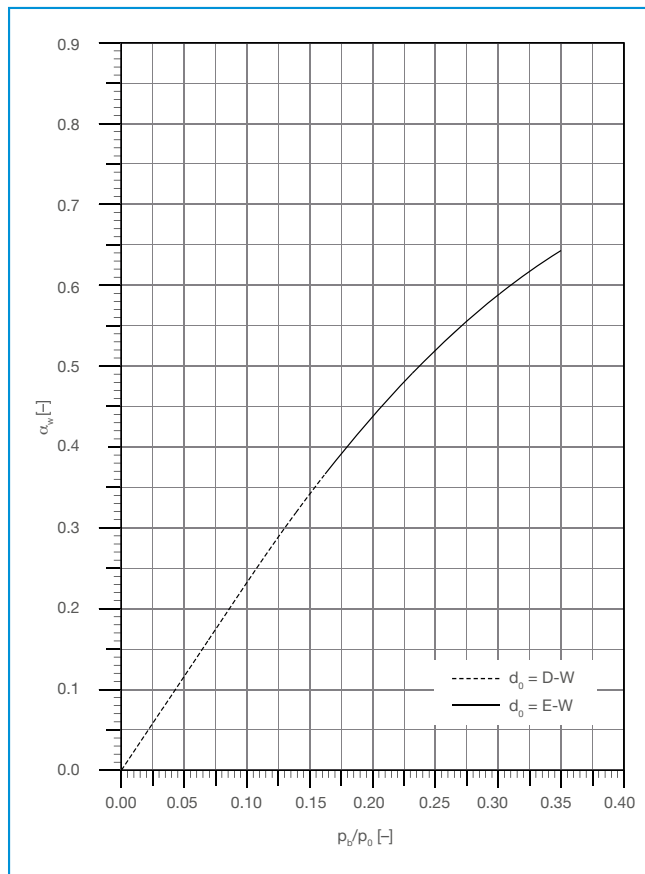
 The certified area 3207 mm^2 is greater than the required area and orifice N a suitable selection. Due to the superimposed back pressure a balanced bellows design is required and the safety valve Si 8403 G 00, NPS 4 Cl. 300 x NPS 6 Cl. 150, orifice N is suitable for the application.

 Si 830 coefficient of discharge α_w depending on p_b/p_0 for liquid

 The coefficients of discharge K_{dr} acc. to DIN EN ISO 4126-1 for this valve series are identical with above coefficients of discharge α_w and the values in the diagrams.

- h = Lift [mm]
- d_0 = Flow diameter of the selected safety valve [mm]
- h/d_0 = Lift/Flow diameter ratio
- p_b = Absolute back pressure [bar a]
- p_0 = Absolute relieving pressure [bar a]
- p_b/p_0 = Absolute back pressure/absolute relieving pressure ratio
- α_w = Coefficient of discharge acc. to AD 2000-Merkblatt A2
- q_m = Required mass flow [kg/hr]
- q_{mc} = Certified mass flow [kg/hr]

Si 830

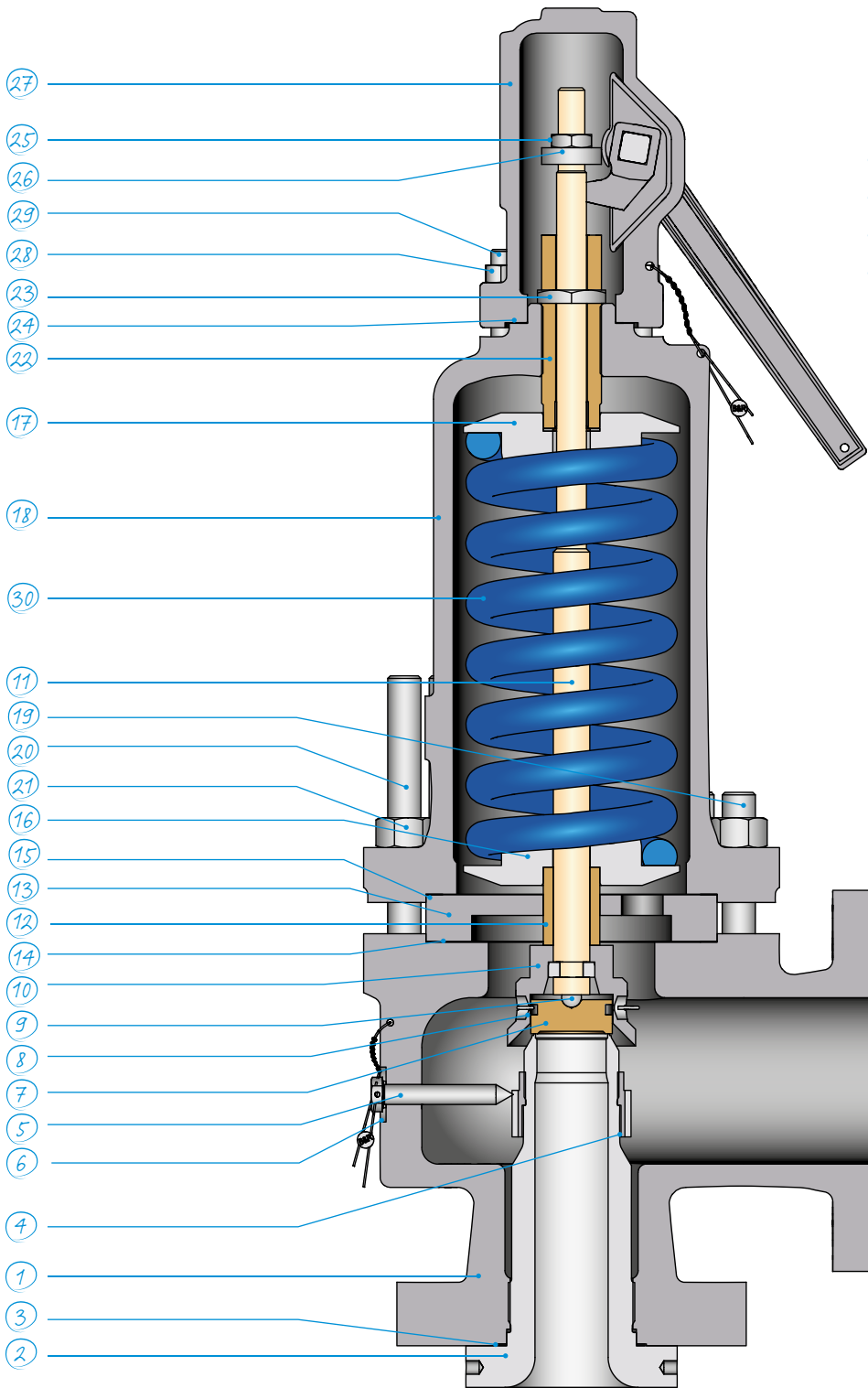
Material code



Bellows design Si 84

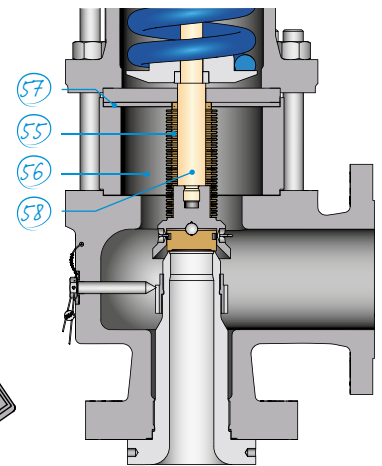

Si 830

Material code			00	01	22	04
Temperature application range			Standard 20 °F to 800 °F -29 °C to 427 °C	High temp. -20 °F to 1000 °F -29 °C to 538 °C	Low temp. -51 °F to 800 °F (-46 °C to 343 °C)	Stainless steel -450 °F to 1000 °F -268 °C to 538 °C
Part	Name	Spare part	Material	Material	Material	Material
1	Body		SA-216 WCB 1.0619	SA-217M WC6 1.7357	SA 352 LCB 1.6220	SA-351 CF8M 1.4408
2	Nozzle	*3	SA-182M Gr. 316L ¹⁾ 1.4404 ¹⁾	SA-479 Gr. 316Ti ¹⁾ 1.4404 ¹⁾	SA-182M Gr. 316L ¹⁾ 1.4404 ¹⁾	SA-182M Gr. 316L ¹⁾⁴⁾ 1.4404 ¹⁾⁴⁾
3	Flat gasket	*1, 2, 3	1.4401 / Graphite	1.4401 / Graphite	1.4401 / Graphite	1.4401 / Graphite
4	Nozzle ring		SA-351 CF8M 1.4408	SA-351 CF8M 1.4408	SA-351 CF8M 1.4408	SA-351 CF8M 1.4408
5	Set screw		A4-70	A4-70	A4-70	A4-70
6	Flat gasket	*1, 2, 3	Soft iron	Soft iron	Soft iron	Soft iron
7	Disc	*2, 3	SA-479M Type 316 L 1.4404	SA-479M Type 316Ti 1.4571	SA-479M Type 316 L 1.4404	SA-479M Type 316 L 1.4404
8	Disc retainer		SA-479M Type 316 L 1.4404	SA-479M Type 316 L 1.4404	SA-479M Type 316 L 1.4404	SA-479M Type 316 L 1.4404
9	Ball		Stainless steel	Stainless steel	Stainless steel	Ceramic
10	Disc holder		MT 440 ^{2) 5)} 1.4122	MT 440 ^{2) 5)} 1.4122	MT 440 ^{2) 5)} 1.4122	SA-479M ⁵⁾ Type 316 L 1.4404
11	Spindle		420 1.4021	420 1.4021	420 1.4021	SA-479M Type 316 L 1.4404
12	Guide bushing		MT 440 ²⁾ 1.4122	MT 440 ²⁾ 1.4122	MT 440 ²⁾ 1.4122	SA-479M Type 316 L 1.4404
13	Guide		MT 440 ²⁾ 1.4122	MT 440 ²⁾ 1.4122	MT 440 ²⁾ 1.4122	SA-479M Type 316 L 1.4404
14	Flat gasket	*1, 2, 3	1.4401 / Graphite	1.4401 / Graphite	1.4401 / Graphite	1.4401 / Graphite
15	Flat gasket	*1, 2, 3	1.4401 / Graphite	1.4401 / Graphite	1.4401 / Graphite	1.4401 / Graphite
16	Spring washer, bottom		Carbon steel	Carbon steel	Carbon steel	Stainless steel
17	Spring washer, top		Carbon steel	Carbon steel	Carbon steel	Stainless steel
18	Bonnet		SA-216 WCB 1.0619	SA-217M WC6 1.7357	SA 352 LCB 1.6220	SA-351 CF8M 1.4408
19	Stud, short		SA 193M Gr. B7	SA 193M Gr. B7	SA 193M Gr. B8M	SA-193M Gr. B8M
20	Stud, long		SA 193M Gr. B7	SA 193M Gr. B7	SA 193M Gr. B8M	SA-193M Gr. B8M
21	Hex nut, bonnet		SA-194M Gr. 2H	SA-194M GRADE 2H	SA-194M GRADE 8M	SA-194M GRADE 8M
22	Adjusting screw		SA-479M Type 316 L 1.4404	SA-479M Type 316 L 1.4404	SA-479M Type 316 L 1.4404	SA-479M Type 316 L 1.4404
23	Adj. screw nut		SA-479M Type 316 L 1.4404	SA-479M Type 316 L 1.4404	SA-479M Type 316 L 1.4404	SA-479M Type 316 L 1.4404
24	Flat gasket	*1, 2, 3	1.4401 / Graphite	1.4401 / Graphite	1.4401 / Graphite	1.4401 / Graphite
25	Spindle nut		Carbon steel	Carbon steel	Carbon steel	SA-479M Type 316 L 1.4404
26	Nut		SA-194M GRADE 2H	SA-194M GRADE 2H	SA-194M GRADE 8M	SA-194M GRADE 8M
27	Cap		SA-216 WCB 1.0619	SA-216 WCB 1.0619	SA 352 LCB 1.6220	SA-351 CF8M 1.4408
28	Stud		SA 193M Gr. B7	SA 193M Gr. B7	SA 193M Gr. B8M	SA-193M Gr. B8M
29	Hex nut, cap		SA-194M Gr. 2H	SA-194M GRADE 2H	SA-194M GRADE 8M	SA-194M GRADE 8M
30	Spring	*3	Alloy steel	Alloy steel	Alloy steel	ASTM 302 ³⁾ 1.4310 ³⁾
55	Bellows	*3	1.4404 SA-479M Type 316 L	1.4404 SA-479M Type 316 L	1.4404 SA-479M Type 316 L	1.4404 SA-479M Type 316 L
56	Intermediate bush		1.0619 SA-216 WCB	1.7357 SA-217M WC6	1.0417 SA 352 LCB	1.4408 SA-351 CF8M
57	Top plate		1.4404 SA-479M Type 316 L	1.4404 SA-479M Type 316 L	1.4404 SA-479M Type 316 L	1.4404 SA-479M Type 316 L
58	Lift stop bushing		1.4404 SA-479M Type 316 L	1.4404 SA-479M Type 316 L	1.4404 SA-479M Type 316 L	1.4404 SA-479M Type 316 L

¹⁾ For orifice Q; R; T the nozzle material is CF8M / 1.4408

²⁾ X 39 CrMo 17-1

³⁾ In case of large valve size and high pressure spring material may be Chrome steel nickel plated

⁴⁾ In case the Temperature is above 427 °C, the nozzle material is SA 479 Gr. 316Ti/1.4571

⁵⁾ For orifice Q; R; T the disc holder material is CF8M / 1.4408

Spare Parts:

*1 Expendable parts, should be replaced as part of any revision if a damage is visible.

*2 Rework spare parts, should be replaced if a rework is no longer possible.

*3 Long life spare parts, replacement may be required after several years of operation.

IMI Bopp & Reuther reserve the right to technical changes or application of higher quality materials without prior notice. The material design can be tailored to customer specifications at any time upon request.

Trim code

Si 8 Monel

Monel is a nickel and copper based alloy mainly used in offshore applications and alkylation reactions. The material shows high corrosion resistance against fluids like sea-water, distilled water, most of organic acids, sulphuric and hydrofluoric acid, alkaline solution, ammonium sulfate (NH₂SO₄ fertilizer),

ammonium chloride (NH₄Cl salmiak), neutral and alkaline saline solution, hydrofluoric acid (HF) and mercury (Hg). The high temperature strength may be another reason to select Monel. The loss of heat resistance is small up to a temperature of 400° C.

At low pressure and low temperature the selection of Monel for medium wetted parts in closed safety valve position may be sufficient (trim code M1). Trim codes (M2) or (M3) are applicable at high corrosion resistance requirements.

Trim code		M1		M2		M3	
		Monel for wetted parts in valve closed position only		(For bellows valves Si 84 only) Monel for all trim parts within the flow chamber sealed by the bellows		All trim parts in Monel	
Ref. No. on the drawing	Part Name	Material	Material ASME	Material	Material ASME	Material	Material ASME
1	Body						
2	Nozzle	2.4360	SB-564 (N04400) (Monel 400)	2.4360	SB-564 (N04400) (Monel 400)	2.4360	SB-564 (N04400) (Monel 400)
3	Flat gasket				Monel/Graphite		Monel/Graphite
4	Nozzle ring			2.4360	SB-564 (N04400) (Monel 400)	2.4360	SB-564 (N04400) (Monel 400)
5	Set screw			2.4360	SB-564 (N04400) (Monel 400)	2.4360	SB-564 (N04400) (Monel 400)
6	Gasket			2.4360	SB-564 (N04400) (Monel 400)	2.4360	SB-564 (N04400) (Monel 400)
7	Disc	2.4375	B865 (N05500) (Monel 500)	2.4375	B865 (N05500) (Monel 500)	2.4375	B865 (N05500) (Monel 500)
8	Disc retainer			2.4375	B865 (N05500) (Monel 500)	2.4375	B865 (N05500) (Monel 500)
9	Ball					Ceramic (B865 (N05500) / (Monel 500 available upon request)	
10	Disc holder			2.4360	SB-564 (N04400) (Monel 400)	2.4360	SB-564 (N04400) (Monel 400)
11	Spindle					2.4360	SB-564 (N04400) (Monel 400)
12	Guide bushing					2.4375	B865 (N05500) (Monel 500)
13	Guide					2.4360	SB-564 (N04400) (Monel 400)
14, 15	Flat gasket				Monel/Graphite		Monel/Graphite
16	Spring washer					2.4360	SB-564 (N04400) (Monel 400)
17	Spring					Inconel X750 or Monel available upon request	
22	Adjusting screw					2.4360	SB-564 (N04400) (Monel 400)
23	Adj. screw nut					2.4360	SB-564 (N04400) (Monel 400)
24	Gasket						Monel/Graphite
25	Spindle nut					2.4360	SB-564 (N04400) (Monel 400)
26	Nut					2.4360	SB-564 (N04400) (Monel 400)
27	Cap						
55	Bellows			2.4360	SB-564 (N04400) (Monel 400)	2.4360	SB-564 (N04400) (Monel 400)
56	Intermediate bush						
57	Top plate			2.4360	SB-564 (N04400) (Monel 400)	2.4360	SB-564 (N04400) (Monel 400)
58	Lift stop bushing					2.4360	SB-564 (N04400) (Monel 400)

The trim materials indicated above are the variations from standard materials of construction. The trim codes can be selected with any standard material class. Valve type Si 8303 G 00 with standard WCB body/bonnet design material class 00 will change to Si 8303 G 00M3 for trim parts in Monel.

Trim code

Si 8 Hastelloy

Hastelloy C is a highly corrosion resistant nickel-chromium-molybdenum alloy and is characterized by high resistance to crevice corrosion, pitting corrosion and stress corrosion cracking in oxidizing and reducing media. The material shows good corrosion resistance to strong oxidizing agents such

as iron (III) chloride and copper (II) chloride, hot media, such as sulfuric acid, nitric acid, phosphoric acid, chlorine (dry), formic acid and acetic acid. Hastelloy is also good resistant to moist chlorine gas, sodium hypochlorite and chlorine dioxide.

At low pressure and low temperature the selection of Hastelloy for medium wetted parts in closed safety valve position may be sufficient (trim code H1). Trim codes (H2) or (H3) are applicable at high corrosion resistance requirements.

Trim code		H1		H2		H3	
		Hastelloy for wetted parts in valve closed position only		(For bellows valves only) Hastelloy for all trim parts within the flow chamber sealed by the bellows		All trim parts in Hastelloy	
Ref. No. on the drawing	Part Name	Material	Material ASME	Material	Material ASME	Material	Material ASME
1	Body						
2	Nozzle	2.4819	Hastelloy C-276	2.4819	Hastelloy C-276	2.4819	Hastelloy C-276
3	Flat gasket					Monel/Graphite	
4	Nozzle ring			2.4819	Hastelloy C-276	2.4819	Hastelloy C-276
5	Set screw			2.4819	Hastelloy C-276	2.4819	Hastelloy C-276
6	Gasket			2.4360	Monel / Graphite	2.4360	Monel / Graphite
7	Disc	2.4819	Hastelloy C-276	2.4819	Hastelloy C-276	2.4819	Hastelloy C-276
8	Disc retainer				Hastelloy C (Ni 6275)		Hastelloy C (Ni 6275)
9	Ball					Ceramic	
10	Disc holder			2.4819	Hastelloy C-276	2.4819	Hastelloy C-276
11	Spindle					2.4819	Hastelloy C-276
12	Guide bushing					2.4819	Hastelloy C-276
13	Guide					2.4819	Hastelloy C-276
14, 15	Flat gasket					Monel/Graphite	
16	Spring washer					2.4819	Hastelloy C-276
17	Spring					Inconel X750 or Hastelloy C available upon request	
22	Adjusting screw					2.4819	Hastelloy C-276
23	Adj. screw nut					2.4819	Hastelloy C-276
24	Gasket						Monel/Graphite
25	Spindle nut					2.4819	Hastelloy C-276
26	Nut					2.4819	Hastelloy C-276
27	Cap						
55	Bellows			2.4819	Hastelloy C-276	2.4819	Hastelloy C-276
56	Intermediate bush						
57	Top plate			2.4819	Hastelloy C-276	2.4819	Hastelloy C-276
58	Lift stop bushing					2.4819	Hastelloy C-276

The trim materials indicated above are the variations from standard materials of construction. The trim codes can be selected with any standard material class. Valve type Si 8403 G 00 with standard WCB body/bonnet design material class 00 will be change to Si 8403 G 00H2 for trim parts in Hastelloy.

Trim code

Si 8 Duplex

Duplex is frequently used in offshore installations in the oil and gas production as well as onshore plants. Duplex is resistant to corrosive media, such as CO₂, H₂S,

chlorides, low pH value fluids and corrosive environment. The increased strength may be another reason for selection.

At low pressure and low temperature, it may suffice that the wetted parts in the closed valve position are made of Duplex (code D1), at high risk of corrosion codes D2 or D3 are preferred.

Trim code		D1		D2		D3	
		Duplex for wetted parts in valve closed position only		(For bellows valves only) Duplex for all trim parts within the flow chamber sealed by the bellows		All trim parts in Duplex	
Ref. No. on the drawing	Part Name	Material	Material ASME	Material	Material ASME	Material	Material ASME
1	Body						
2	Nozzle	1.4462	SA-182M Grade F51 UNS S31803	1.4462	SA-182M Grade F51 UNS S31803	1.4462	SA-182M Grade F51 UNS S31803
3	Flat gasket				Monel/Graphite		Monel/Graphite
4	Nozzle ring			1.4462	SA-182M Grade F51 UNS S31803	1.4462	SA-182M Grade F51 UNS S31803
5	Set screw			1.4462	SA-182M Grade F51 UNS S31803	1.4462	SA-182M Grade F51 UNS S31803
6	Gasket				Monel/Graphite		Monel/Graphite
7	Disc	1.4462	SA-182M Grade F51 UNS S31803	1.4462	SA-182M Grade F51 UNS S31803	1.4462	SA-182M Grade F51 UNS S31803
8	Disc retainer			2.4669	Inconel X750	2.4669	Inconel X750
9	Ball					Ceramic	
10	Disc holder			1.4462	SA-182M Grade F51 UNS S31803	1.4462	SA-182M Grade F51 UNS S31803
11	Spindle					1.4462	SA-182M Grade F51 UNS S31803
12	Guide bushing					1.4462	SA-182M Grade F51 UNS S31803
13	Guide					1.4462	SA-182M Grade F51 UNS S31803
14, 15	Flat gasket			Monel/Graphite			Monel/Graphite
16	Spring washer					1.4462	SA-182M Grade F51 UNS S31803
17	Spring					Inconel X750	
22	Adjusting screw					1.4462	SA-182M Grade F51 UNS S31803
23	Adj. screw nut					1.4462	SA-182M Grade F51 UNS S31803
24	Gasket						Monel/Graphite
25	Spindle nut					1.4462	SA-182M Grade F51 UNS S31803
26	Nut					1.4462	SA-182M Grade F51 UNS S31803
27	Cap						
55	Bellows			2.4856	Inconel 625	2.4856	Inconel 625
56	Intermediate bush						
57	Top plate			2.4856	Inconel 625	2.4856	Inconel 625
58	Lift stop bushing					1.4462	SA-182M Grade F51 UNS S31803

The trim materials indicated above are the variations from standard materials of construction. The trim codes can be selected with any standard material class. Valve type Si 8303 G 00 with standard WCB body/bonnet design material class 00 will be changed to Si 8303 G 00D3 for trim parts in Duplex.

Trim code

Si 8 NACE

NACE Standards MR0103-2012 and NACE MR0175/ISO 15156 can be applied to systems processing sour gas, provided the absolute pressure is equal or greater 65 psi (0,45 MPa) and H2S partial pressure is equal or greater 0.05 psi (0,3 kPa). In op-

tions N3 or N4 it behaves like the described absolute pressure and the H₂S partial pressure in the outlet zone under operating (constant back pressure) or relieving conditions. Otherwise, Options Trim Code N1 or Trim Code N2 can be applied.

Note:

Guidance to calculation of H₂S partial pressure:

P = is the total absolute pressure in the system (MPa)

C_{H₂S} = is the mole fraction of H₂S (%)

$$P_{H_2S} = P \cdot \frac{C_{H_2S}}{100}$$

Trim code		N1		N2		N3		N4	
		(conventional valves) Outlet not under sour gas exposure. See note above.		(bellows valves) Outlet not under sour gas exposure.		(conventional valves) Valve outlet under sour gas exposure.		(bellows valves) Valve outlet pressure under sour gas exposure.	
Ref. No. on the drawing	Part Name	Material	Material ASME	Material	Material ASME	Material	Material ASME	Material	Material ASME
1	Body								
2	Nozzle	1.4404	SA-182M Gr. 316L	1.4404	SA-182M Gr. 316L	1.4404	SA-182M Gr. 316L	1.4404	SA-182M Gr. 316L
3	Flat gasket								
4	Nozzle ring					1.4408	SA-351 CF8M	1.4408	SA-351 CF8M
5	Set screw					1.4404	SA-182M Gr. 316L	1.4404	SA-182M Gr. 316L
6	Gasket								
7	Disc	1.4404	SA-182M Gr. 316L	1.4404	SA-182M Gr. 316L	1.4404	SA-182M Gr. 316L	1.4404	SA-182M Gr. 316L
8	Disc retainer								
9	Ball							Ceramic	
10	Disc holder					1.4404	SA-182M Gr. 316L	1.4404	SA-182M Gr. 316L
11	Spindle					1.4404	SA-182M Gr. 316L		
12	Guide bushing					1.4404	SA-182M Gr. 316L		
13	Guide					1.4404	SA-182M Gr. 316L		
14, 15	Flat gasket							1.4401/Graphite	
16	Spring washer					1.4404	SA-182M Gr. 316L		
17	Spring					2.4669	Inconel X750		
22	Adjusting screw								
23	Adj. screw nut								
24	Gasket								
25	Spindle nut					1.4404	SA-182M Gr. 316L		
26	Nut						A4-70		
27	Cap								
55	Bellows							2.4856	Inconel 625
56	Intermediate bush								
57	Top plate							1.4404	SA-182M Gr. 316L
58	Lift stop bushing					1.4404	SA-182M Gr. 316L		

The trim materials indicated above are the variations from standard materials of construction. The trim codes can be selected with any standard material class. Valve type Si 8303 G 00 with standard WCB body/bonnet design material class 00 will be change to Si 8303 G 00N1 for trim parts for NACE applications.

Orifice D

Minimum set pressures

Si 830x.57	4	psig	0.24	bar g
Si 830x	8	psig	0.5	bar g
Si 840x	22	psig	1.5	bar g

Effective area 0.110 in² / 71 mm²

Inlet class	01	02	03	04	05	06	07	
Class	150 x 150	300 x 150	300 x 150	600 x 150	900 x 300	1500 x 300	2500 x 300	
NPS Inlet x outlet	1" x 2"	1" x 2"	1" x 2"	1" x 2"	1 1/2" x 2"	1 1/2" x 2"	1 1/2" x 3"	
S1 [in]	4.50	4.50	4.50	4.50	5.50	5.50	7.00	
S2 [in]	4.13	4.13	4.13	4.13	4.13	4.13	5.50	
X [in]	1.73	1.73	1.73	1.73	2.24	2.24	2.83	
H1 Si 81/83 [in]	17.32	17.32	17.32	17.32	20.67	20.67	26.57	
H2 Si 84/85 [in]	19.09	19.09	19.09	19.09	22.64	22.64	28.74	
Weight Si 81/83 [lbs]	34	36	36	36	62	62	106	
Weight Si 84/85 [lbs]	36	38	38	38	69	69	113	
Inlet temperature	Max. set pressure [psig]							Material code
-51 °F to -21 °F	266	266	696	1392	2089	3481	5801	22 LCB
-20 °F to 100 °F	285	285	740	1480	2220	3705	6000	00 WCB
101 °F to 450 °F	185	285	615	1235	1845	3080	5135	
451 °F to 800 °F	80	285	410	825	1235	2060	3430	01 WC6
451 °F to 800 °F			510	1015	1525	2540	4230	
801 °F to 1000 °F			215	430	650	1080	1800	04 CF8M
-450 °F to -76 °F	275	275	720	1440	2160	3600	4000	
-75 °F to -21 °F	275	275	720	1440	2160	3600	6000	
-20 °F to -100 °F	275	275	720	1440	2160	3600	6000	
101 °F to 450 °F	180	275	495	975	1485	2480	4130	
451 °F to 800 °F	80	275	420	845	1265	2110	3520	
801 °F to 1000 °F	20	275	350	700	1050	1750	2915	
Outlet temperature	Max. outlet pressure [psig]							
Si 81/83@100 °F	265	265	265	265	600	600	695	22
Si 81/83@100 °F	285	285	285	285	600	600	740	00/01
Si 81/83@100 °F	275	275	275	275	600	600	720	04
Si 84/85@100 °F	230	230	230	230	500	500	500	all

Inlet class	01	02	03	04	05	06	07	
Class	150 x 150	300 x 150	300 x 150	600 x 150	900 x 300	1500 x 300	2500 x 300	
NPS Inlet x outlet	1" x 2"	1" x 2"	1" x 2"	1" x 2"	1 1/2" x 2"	1 1/2" x 2"	1 1/2" x 3"	
S1 [mm]	114.3	114.3	114.3	114.3	139.7	139.7	177.8	
S2 [mm]	104.8	104.8	104.8	104.8	104.8	104.8	139.7	
X [mm]	44	44	44	44	57	57	72	
H1 Si 81/83 [mm]	440	440	440	440	525	525	675	
H2 Si 84/85 [mm]	485	485	485	485	575	575	730	
Weight Si 81/83 [kg]	15	16	16	16	28	28	48	
Weight Si 84/85 [kg]	16	17	17	17	31	31	51	
Inlet temperature	Max. set pressure [bar g]							Material code
-46 °C to -30 °C	18.3	18.3	48.0	96.0	144.0	240.0	400.0	22 LCB
-29 °C to 38 °C	19.7	19.7	51.0	102.0	153.1	255.5	413.7	00 WCB
39 °C to 232 °C	12.8	19.7	42.4	85.2	127.2	212.4	354.0	
233 °C to 427 °C	5.5	19.7	28.3	56.9	85.2	142.0	236.5	01 WC6
233 °C to 427 °C			35.2	70.0	105.1	175.1	291.6	
428 °C to 538 °C			14.8	29.6	44.8	74.5	124.1	04 CF8M
-268 °C to -60 °C	19.0	19.0	49.6	99.3	148.9	248.2	275.8	
-59 °C to -30 °C	19.0	19.0	49.6	99.3	148.9	248.2	413.7	
-29 °C to 38 °C	19.0	19.0	49.6	99.3	148.9	248.2	413.7	
39 °C to 232 °C	12.4	19.0	34.1	67.2	102.4	171.0	284.8	
233 °C to 427 °C	5.5	19.0	29.0	58.3	87.2	145.5	242.7	
428 °C to 538 °C	1.4	19.0	24.1	48.3	72.4	120.7	201.0	
Outlet temperature	Max. outlet pressure [bar g]							
Si 81/83@38 °C	18.3	18.3	18.3	18.3	41.4	41.4	47.9	22
Si 81/83@38 °C	19.7	19.7	19.7	19.7	41.4	41.4	51.0	00/01
Si 81/83@38 °C	19.0	19.0	19.0	19.0	41.4	41.4	49.6	04
Si 84/85@38 °C	15.9	15.9	15.9	15.9	34.5	34.5	34.5	all

Orifice D

Selection chart

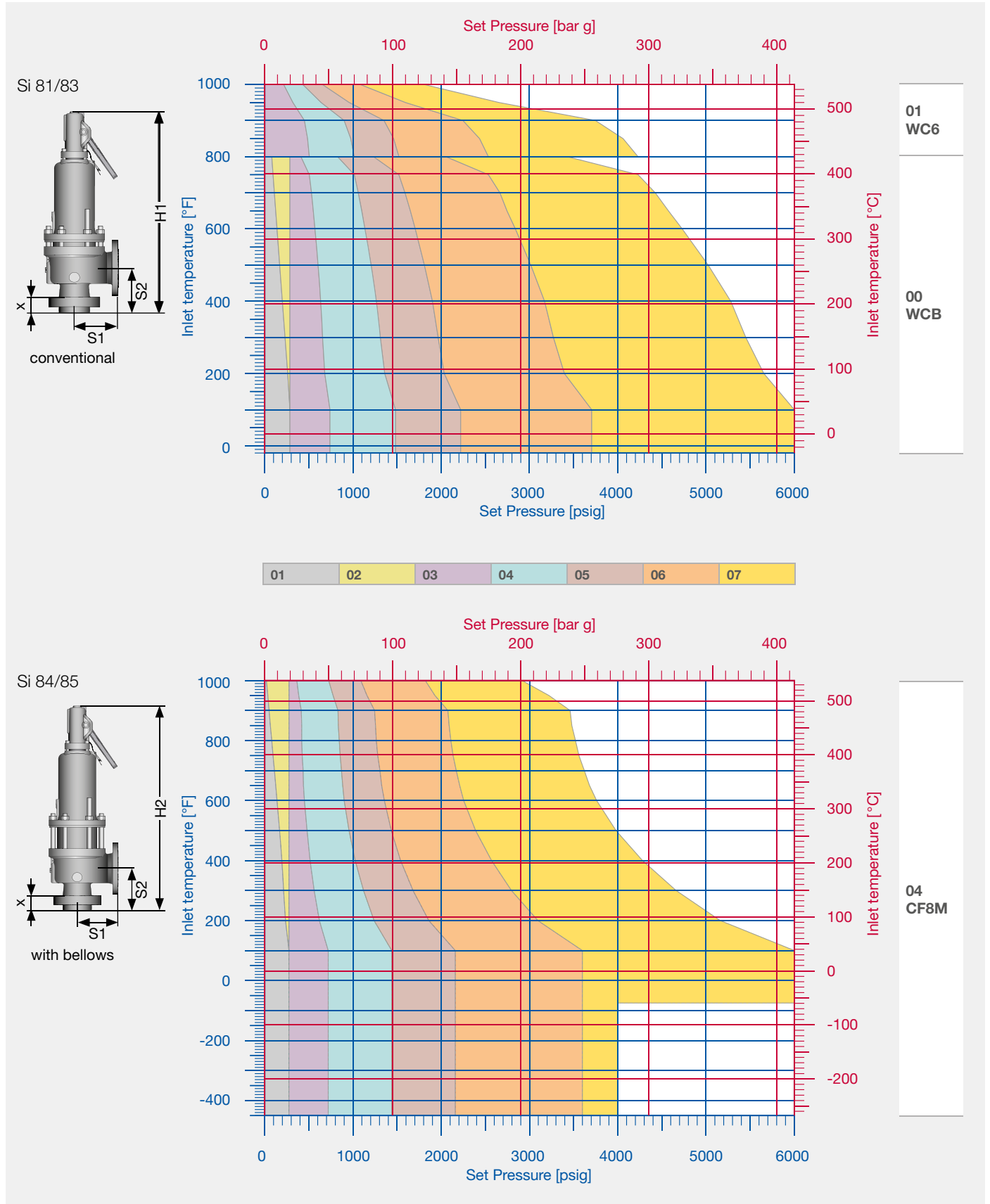

Orifice E

Minimum set pressures

Si 830x.57	4	psig	0.24	bar g
Si 830x	8	psig	0.5	bar g
Si 840x	22	psig	1.5	bar g

Effective area 0.196 in² / 126 mm²

Inlet class	01	02	03	04	05	06	07	
Class	150 x 150	300 x 150	300 x 150	600 x 150	900 x 300	1500 x 300	2500 x 300	
NPS Inlet x outlet	1" x 2"	1" x 2"	1" x 2"	1" x 2"	1 1/2" x 2"	1 1/2" x 2"	1 1/2" x 3"	
S1 [in]	4.50	4.50	4.50	4.50	5.50	5.50	7.00	
S2 [in]	4.13	4.13	4.13	4.13	4.13	4.13	5.50	
X [in]	1.73	1.73	1.73	1.73	2.24	2.24	2.83	
H1 Si 81/83 [in]	17.32	17.32	17.32	17.32	20.67	20.67	26.57	
H2 Si 84/85 [in]	19.09	19.09	19.09	19.09	22.64	22.64	28.74	
Weight Si 81/83 [lbs]	34	36	36	36	62	62	106	
Weight Si 84/85 [lbs]	36	38	38	38	69	69	113	
Inlet temperature	Max. set pressure [psig]							Material code
-51 °F to -21 °F	266	266	696	1392	2089	3481	5801	22 LCB
-20 °F to 100 °F	285	285	740	1480	2220	3705	6000	00 WCB
101 °F to 450 °F	185	285	615	1235	1845	3080	5135	
451 °F to 800 °F	80	285	410	825	1235	2060	3430	01 WC6
451 °F to 800 °F			510	1015	1525	2540	4230	
801 °F to 1000 °F			215	430	650	1080	1800	04 CF8M
-450 °F to -76 °F	275	275	720	1440	2160	3600	4000	
-75 °F to -21 °F	275	275	720	1440	2160	3600	6000	
-20 °F to -100 °F	275	275	720	1440	2160	3600	6000	
101 °F to 450 °F	180	275	495	975	1485	2480	4130	
451 °F to 800 °F	80	275	420	845	1265	2110	3520	
801 °F to 1000 °F	20	275	350	700	1050	1750	2915	
Outlet temperature	Max. outlet pressure [psig]							
Si 81/83@100 °F	265	265	265	265	600	600	695	22
Si 81/83@100 °F	285	285	285	285	600	600	740	00/01
Si 81/83@100 °F	275	275	275	275	600	600	720	04
Si 84/85@100 °F	230	230	230	230	500	500	500	all

Inlet class	01	02	03	04	05	06	07	
Class	150 x 150	300 x 150	300 x 150	600 x 150	900 x 300	1500 x 300	2500 x 300	
NPS Inlet x outlet	1" x 2"	1" x 2"	1" x 2"	1" x 2"	1 1/2" x 2"	1 1/2" x 2"	1 1/2" x 3"	
S1 [mm]	114.3	114.3	114.3	114.3	139.7	139.7	177.8	
S2 [mm]	104.8	104.8	104.8	104.8	104.8	104.8	139.7	
X [mm]	44	44	44	44	57	57	72	
H1 Si 81/83 [mm]	440	440	440	440	525	525	675	
H2 Si 84/85 [mm]	485	485	485	485	575	575	730	
Weight Si 81/83 [kg]	15	16	16	16	28	28	48	
Weight Si 84/85 [kg]	16	17	17	17	31	31	51	
Inlet temperature	Max. set pressure [bar g]							Material code
-46 °C to -30 °C	18.3	18.3	48.0	96.0	144.0	240.0	400.0	22 LCB
-29 °C to 38 °C	19.7	19.7	51.0	102.0	153.1	255.5	413.7	00 WCB
39 °C to 232 °C	12.8	19.7	42.4	85.2	127.2	212.4	354.0	
233 °C to 427 °C	5.5	19.7	28.3	56.9	85.2	142.0	236.5	01 WC6
233 °C to 427 °C			35.2	70.0	105.1	175.1	291.6	
428 °C to 538 °C			14.8	29.6	44.8	74.5	124.1	04 CF8M
-268 °C to -60 °C	19.0	19.0	49.6	99.3	148.9	248.2	275.8	
-59 °C to -30 °C	19.0	19.0	49.6	99.3	148.9	248.2	413.7	
-29 °C to 38 °C	19.0	19.0	49.6	99.3	148.9	248.2	413.7	
39 °C to 232 °C	12.4	19.0	34.1	67.2	102.4	171.0	284.8	
233 °C to 427 °C	5.5	19.0	29.0	58.3	87.2	145.5	242.7	
428 °C to 538 °C	1.4	19.0	24.1	48.3	72.4	120.7	201.0	
Outlet temperature	Max. outlet pressure [bar g]							
Si 81/83@38 °C	18.3	18.3	18.3	18.3	41.4	41.4	47.9	22
Si 81/83@38 °C	19.7	19.7	19.7	19.7	41.4	41.4	51.0	00/01
Si 81/83@38 °C	19.0	19.0	19.0	19.0	41.4	41.4	49.6	04
Si 84/85@38 °C	15.9	15.9	15.9	15.9	34.5	34.5	34.5	all

Orifice E

Selection chart

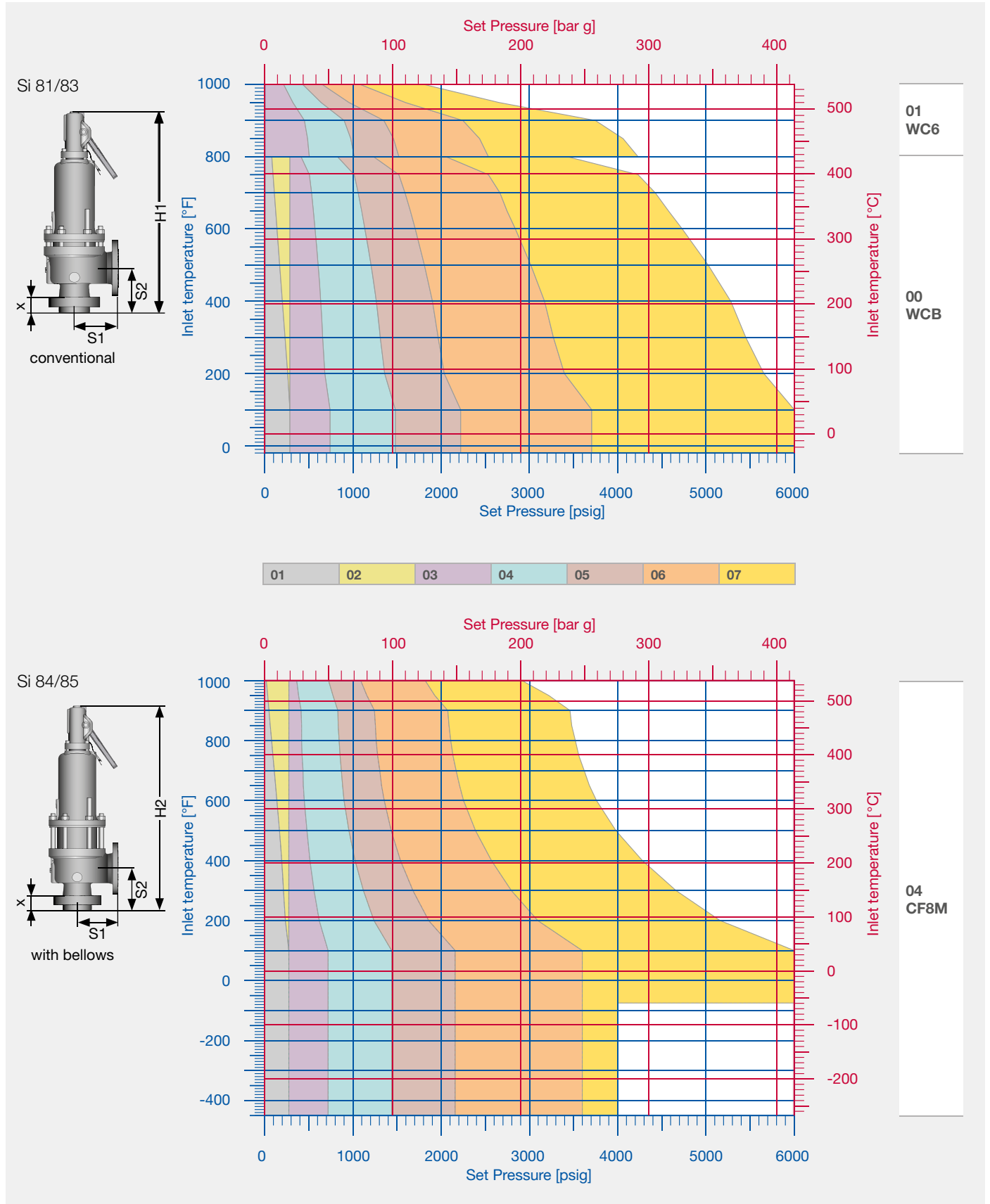

Orifice F

Minimum set pressures

Si 830x.57	3	psig	0.16	bar g
Si 830x	8	psig	0.5	bar g
Si 840x	15	psig	1	bar g

Effective area 0.307 in² / 198 mm²

Inlet class	01	02	03	04	05	06	07	
Class	150 x 150	300 x 150	300 x 150	600 x 150	900 x 300	1500 x 300	2500 x 300	
NPS Inlet x outlet	1 1/2" x 2"	1 1/2" x 2"	1 1/2" x 2"	1 1/2" x 2"	1 1/2" x 3"	1 1/2" x 3"	1 1/2" x 3"	
S1 [in]	4.75	4.75	6.00	6.00	6.50	6.50	7.00	
S2 [in]	4.87	4.87	4.87	4.87	4.87	4.87	5.50	
X [in]	1.65	1.65	1.81	1.81	2.09	2.09	2.83	
H1 Si 81/83 [in]	18.11	18.11	20.47	20.47	26.18	26.18	26.57	
H2 Si 84/85 [in]	20.47	20.47	22.24	22.24	29.13	29.13	29.53	
Weight Si 81/83 [lbs]	38	40	34	56	71	71	111	
Weight Si 84/85 [lbs]	42	45	60	60	80	80	117	
Inlet temperature	Max. set pressure [psig]							Material code
-51 °F to -21 °F	266	266	696	1392	2089	3481	5000	22 LCB
-20 °F to 100 °F	285	285	740	1480	2220	3705	5000	00 WCB
101 °F to 450 °F	185	285	615	1235	1845	3080	5000	
451 °F to 800 °F	80	285	410	825	1235	2060	3430	01 WC6
451 °F to 800 °F			510	1015	1525	2540	4230	
801 °F to 1000 °F			215	430	650	1080	1800	04 CF8M
-450 °F to -76 °F	275	275	720	1440	2160	2200	3400	
-75 °F to -21 °F	275	275	720	1440	2160	3600	5000	
-20 °F to -100 °F	275	275	720	1440	2160	3600	5000	
101 °F to 450 °F	180	275	495	975	1485	2480	4130	
451 °F to 800 °F	80	275	420	845	1265	2110	3520	
801 °F to 1000 °F	20	275	350	700	1050	1750	2915	
Outlet temperature	Max. set pressure [psig]							
Si 81/83@100 °F	265	265	265	265	695	695	695	22
Si 81/83@100 °F	285	285	285	285	740	740	740	00/01
Si 81/83@100 °F	275	275	275	275	600	600	720	04
Si 84/85@100 °F	230	230	230	230	500	500	500	all

Inlet class	01	02	03	04	05	06	07	
Class	150 x 150	300 x 150	300 x 150	600 x 150	900 x 300	1500 x 300	2500 x 300	
NPS Inlet x outlet	1 1/2" x 2"	1 1/2" x 2"	1 1/2" x 2"	1 1/2" x 2"	1 1/2" x 3"	1 1/2" x 3"	1 1/2" x 3"	
S1 [mm]	120.7	120.7	152.4	152.4	165.1	165.1	177.8	
S2 [mm]	123.8	123.8	123.8	123.8	123.8	123.8	139.7	
X [mm]	42	42	46	46	53	53	72	
H1 Si 81/83 [mm]	460	460	520	520	665	665	675	
H2 Si 84/85 [mm]	520	520	565	565	740	740	750	
Weight Si 81/83 [kg]	17	18	25	25	32	32	50	
Weight Si 84/85 [kg]	19	20	27	27	36	36	53	
Inlet temperature	Max. set pressure [bar g]							Material code
-46 °C to -30 °C	18.3	18.3	48.0	96.0	144.0	240.0	344.7	22 LCB
-29 °C to 38 °C	19.7	19.7	51.0	102.0	153.1	255.5	344.7	00 WCB
39 °C to 232 °C	12.8	19.7	42.4	85.2	127.2	212.4	344.7	
233 °C to 427 °C	5.5	19.7	28.3	56.9	85.2	142.0	236.5	01 WC6
233 °C to 427 °C			35.2	70.0	105.1	175.1	291.6	
428 °C to 538 °C			14.8	29.6	44.8	74.5	124.1	04 CF8M
-268 °C to -60 °C	19.0	19.0	49.6	99.3	148.9	151.7	234.4	
-59 °C to -30 °C	19.0	19.0	49.6	99.3	148.9	248.2	344.7	
-29 °C to 38 °C	19.0	19.0	49.6	99.3	148.9	248.2	344.7	
39 °C to 232 °C	12.4	19.0	34.1	67.2	102.4	171.0	284.8	
233 °C to 427 °C	5.5	19.0	29.0	58.3	87.2	145.5	242.7	
428 °C to 538 °C	1.4	19.0	24.1	48.3	72.4	120.7	201.0	
Outlet temperature	Max. outlet pressure [bar g]							
Si 81/83@38 °C	18.3	18.3	18.3	18.3	47.9	47.9	47.9	22
Si 81/83@38 °C	19.7	19.7	19.7	19.7	51.0	51.0	51.0	00/01
Si 81/83@38 °C	19.0	19.0	19.0	19.0	41.4	41.4	49.6	04
Si 84/85@38 °C	15.9	15.9	15.9	15.9	34.5	34.5	34.5	all

Orifice F

Selection chart

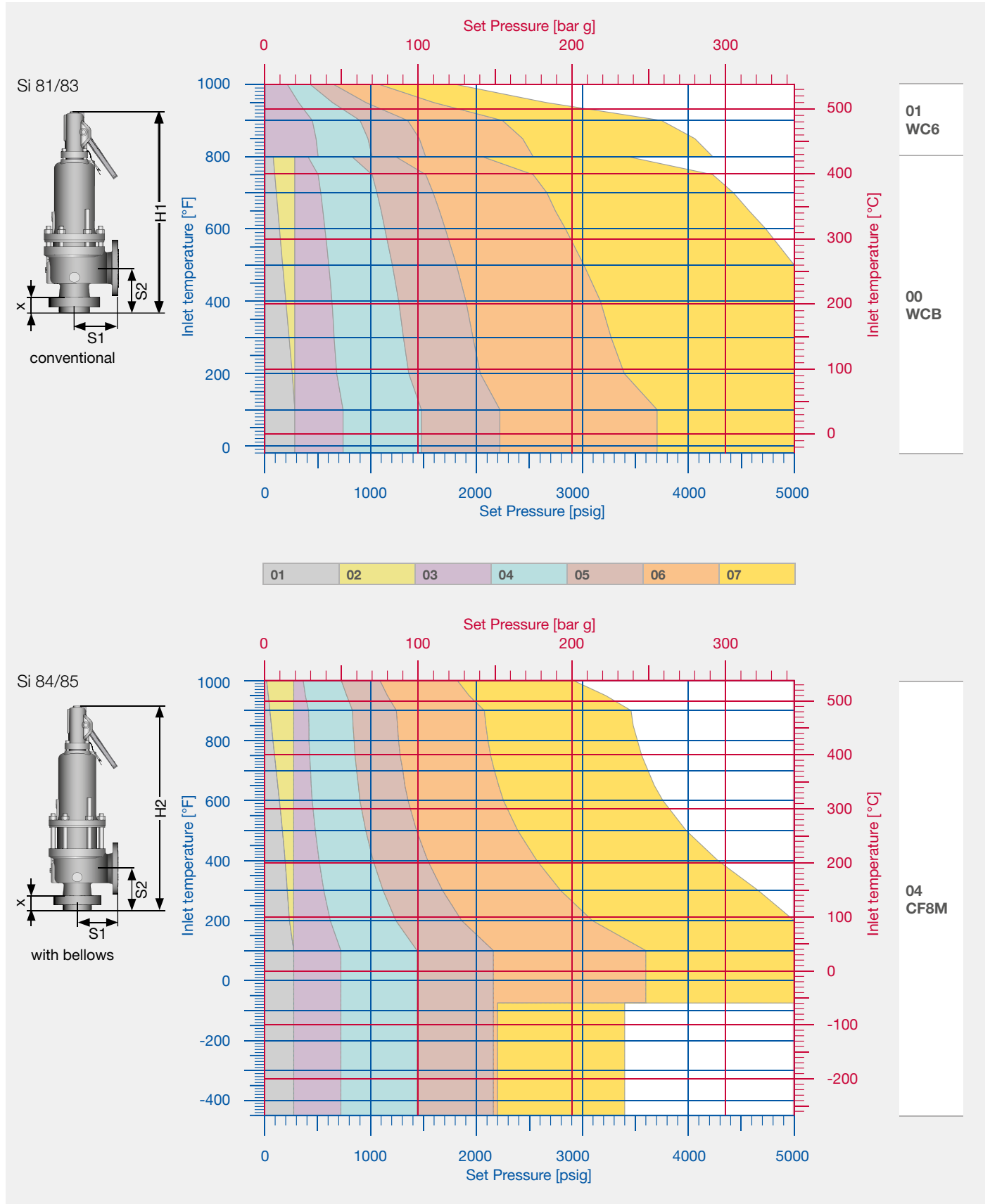

Orifice G

Minimum set pressures

Si 830x.57	2	psig	0.13	bar g
Si 830x	8	psig	0.5	bar g
Si 840x	21	psig	1.4	bar g

Effective area 0.503 in² / 324 mm²

Inlet class	01	02	03	04	05	06	07	
Class	150 x 150	300 x 150	300 x 150	600 x 150	900 x 300	1500 x 300	2500 x 300	
NPS Inlet x outlet	1 1/2" x 3"	1 1/2" x 3"	1 1/2" x 3"	1 1/2" x 3"	1 1/2" x 3"	2" x 3"	2" x 3"	
S1 [in]	4.75	4.75	6.00	6.00	6.50	6.75	6.75	
S2 [in]	4.87	4.87	4.87	4.87	4.87	6.13	6.13	
X [in]	1.65	1.65	1.81	1.81	2.09	3.15	3.15	
H1 Si 81/83 [in]	18.31	18.31	22.05	22.05	26.18	27.95	27.95	
H2 Si 84/85 [in]	20.08	20.08	23.82	23.82	29.13	30.91	30.91	
Weight Si 81/83 [lbs]	40	42	67	67	89	100	115	
Weight Si 84/85 [lbs]	45	51	84	84	95	111	124	
Inlet temperature	Max. set pressure [psig]							Material code
-51 °F to -21 °F	266	266	696	1392	2089	3481	3705	22 LCB
-20 °F to 100 °F	285	285	740	1480	2220	3705	3705	00 WCB
101 °F to 450 °F	185	285	615	1235	1845	3080	3705	
451 °F to 800 °F	80	285	410	825	1235	2060	3430	01 WC6
451 °F to 800 °F			510	1015	1525	2540	3705	
801 °F to 1000 °F			215	430	650	1080	1800	04 CF8M
-450 °F to -76 °F	275	275	720	1440	2160	2450	2600	
-75 °F to -21 °F	275	275	720	1440	2160	3600	3705	
-20 °F to -100 °F	275	275	720	1440	2160	3600	3705	
101 °F to 450 °F	180	275	495	975	1485	2480	3705	
451 °F to 800 °F	80	275	420	845	1265	2110	3520	
801 °F to 1000 °F	20	275	350	700	1050	1750	2915	
Outlet temperature	Max. outlet pressure [psig]							
Si 81/83@100 °F	265	265	265	265	695	695	695	22
Si 81/83@100 °F	285	285	285	285	740	740	740	00/01
Si 81/83@100 °F	275	275	275	275	600	600	720	04
Si 84/85@100 °F	230	230	230	230	470 (500)	470 (500)	470 (500)	00/22 (01/04)

Inlet class	01	02	03	04	05	06	07	
Class	150 x 150	300 x 150	300 x 150	600 x 150	900 x 300	1500 x 300	2500 x 300	
NPS Inlet x outlet	1 1/2" x 3"	1 1/2" x 3"	1 1/2" x 3"	1 1/2" x 3"	1 1/2" x 3"	2" x 3"	2" x 3"	
S1 [mm]	120.7	120.7	152.4	152.4	165.1	171.5	171.5	
S2 [mm]	123.8	123.8	123.8	123.8	123.8	155.6	155.6	
X [mm]	42	42	46	46	53	80	80	
H1 Si 81/83 [mm]	465	465	560	560	665	710	710	
H2 Si 84/85 [mm]	510	510	605	605	740	785	785	
Weight Si 81/83 [kg]	18	19	30	30	40	45	52	
Weight Si 84/85 [kg]	20	23	38	38	43	50	56	
Inlet temperature	Max. set pressure [bar g]							Material code
-46 °C to -30 °C	18.3	18.3	48.0	96.0	144.0	240.0	255.5	22 LCB
-29 °C to 38 °C	19.7	19.7	51.0	102.0	153.1	255.5	255.5	00 WCB
39 °C to 232 °C	12.8	19.7	42.4	85.2	127.2	212.4	255.5	
233 °C to 427 °C	5.5	19.7	28.3	56.9	85.2	142.0	236.5	01 WC6
233 °C to 427 °C			35.2	70.0	105.1	175.1	255.5	
428 °C to 538 °C			14.8	29.6	44.8	74.5	124.1	04 CF8M
-268 °C to -60 °C	19.0	19.0	49.6	99.3	148.9	168.9	179.3	
-59 °C to -30 °C	19.0	19.0	49.6	99.3	148.9	248.2	255.5	
-29 °C to 38 °C	19.0	19.0	49.6	99.3	148.9	248.2	255.5	
39 °C to 232 °C	12.4	19.0	34.1	67.2	102.4	171.0	255.5	
233 °C to 427 °C	5.5	19.0	29.0	58.3	87.2	145.5	242.7	
428 °C to 538 °C	1.4	19.0	24.1	48.3	72.4	120.7	201.0	
Outlet temperature	Max. outlet pressure [bar g]							
Si 81/83@38 °C	18.3	18.3	18.3	18.3	47.9	47.9	47.9	22
Si 81/83@38 °C	19.7	19.7	19.7	19.7	51.0	51.0	51.0	00/01
Si 81/83@38 °C	19.0	19.0	19.0	19.0	41.4	41.4	49.6	04
Si 84/85@38 °C	15.9	15.9	15.9	15.9	32.4 (34.5)	32.4 (34.5)	32.4 (34.5)	00/22 (01/04)

Orifice G

Selection chart

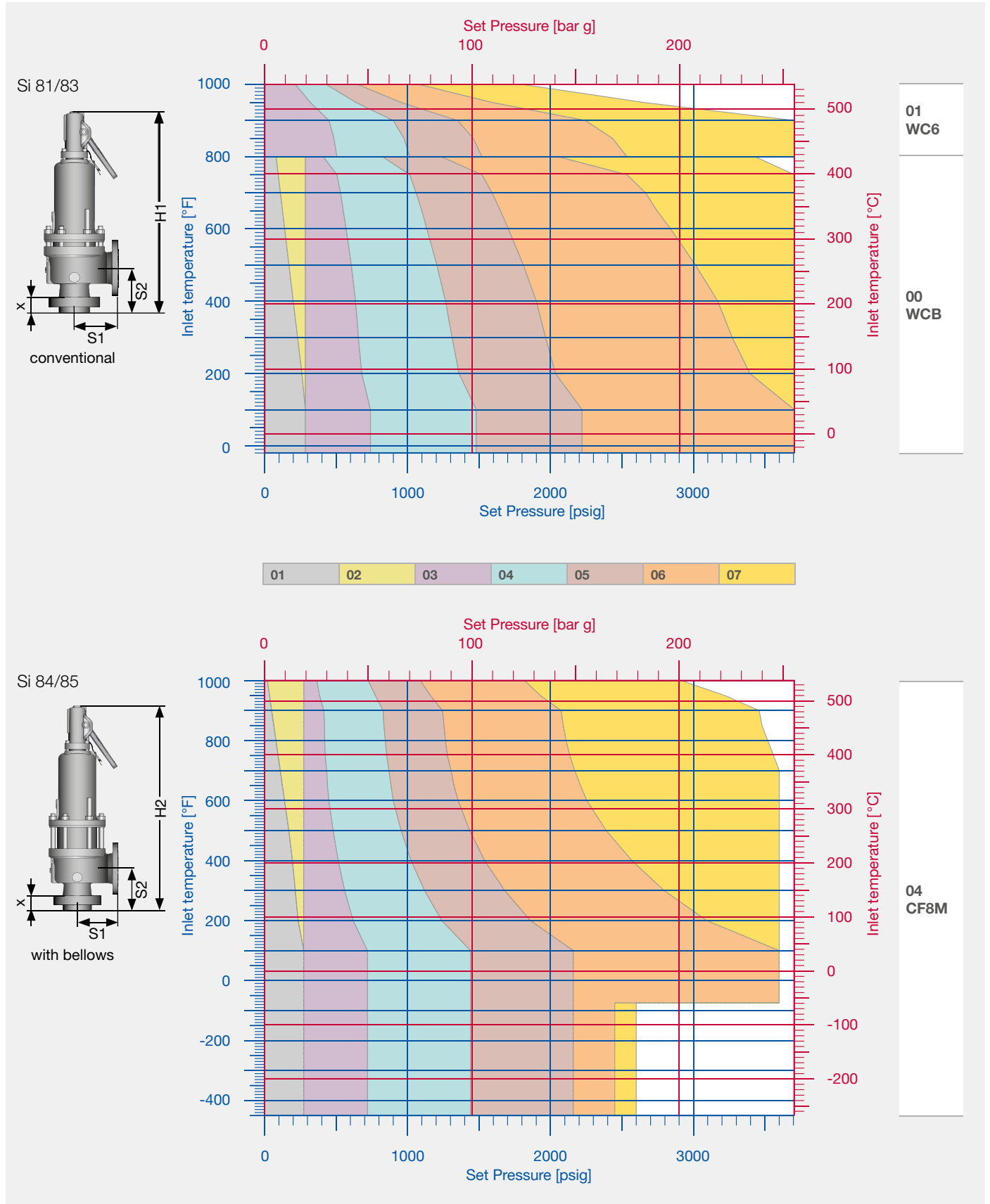

Orifice H

Minimum set pressures

Si 830x.57	4	psig	0.22	bar g
Si 830x	8	psig	0.5	bar g
Si 840x	15	psig	1	bar g

Effective area 0.785 in² / 506 mm²

Inlet class	01	02	03	04	05	06	
Class	150 x 150	300 x 150	300 x 150	600 x 150	900 x 150	1500 x 300	
NPS Inlet x outlet	1 1/2" x 3"	1 1/2" x 3"	2" x 3"	2" x 3"	2" x 3"	2" x 3"	
S1 [in]	4.87	4.87	4.87	6.37	6.37	6.37	
S2 [in]	5.13	5.13	5.13	6.06	6.06	6.06	
X [in]	1.73	1.73	1.89	2.09	2.64	2.64	
H1 Si 81/83 [in]	21.26	21.26	22.64	27.95	27.95	27.95	
H2 Si 84/85 [in]	23.03	23.03	24.80	30.71	30.71	30.71	
Weight Si 81/83 [lbs]	60	62	80	115	139	150	
Weight Si 84/85 [lbs]	64	67	86	133	150	164	
Inlet temperature	Max. set pressure [psig]						Material code
-51 °F to -21 °F	266	266	696	1392	2089	3481	22 LCB
-20 °F to 100 °F	285	285	740	1480	2220	3705	00 WCB
101 °F to 450 °F	185	285	615	1235	1845	3080	
451 °F to 800 °F	80	285	410	825	1235	2060	01 WC6
451 °F to 800 °F			510	1015	1525	2540	04 CF8M
801 °F to 1000 °F			215	430	650	1080	
-450 °F to -76 °F	275	275	720	1440	2160	2450	
-75 °F to -21 °F	275	275	720	1440	2160	3600	
-20 °F to -100 °F	275	275	720	1440	2160	3600	
101 °F to 450 °F	180	275	495	975	1485	2480	
451 °F to 800 °F	80	275	420	845	1265	2110	
801 °F to 1000 °F	20	275	350	700	1050	1750	
Outlet temperature	Max. outlet pressure [psig]						
Si 81/83@100 °F	265	265	265	265	265	695	22
Si 81/83@100 °F	285	285	285	285	285	740	00/01
Si 81/83@100 °F	275	275	275	275	275	600	04
Si 84/85@100 °F	230	230	230	230	230	415	all

Inlet class	01	02	03	04	05	06	
Class	150 x 150	300 x 150	300 x 150	600 x 150	900 x 150	1500 x 300	
NPS Inlet x outlet	1 1/2" x 3"	1 1/2" x 3"	2" x 3"	2" x 3"	2" x 3"	2" x 3"	
S1 [mm]	123.8	123.8	123.8	161.9	161.9	161.9	
S2 [mm]	130.2	130.2	130.2	154.0	154.0	154.0	
X [mm]	44	44	48	53	67	67	
H1 Si 81/83 [mm]	540	540	575	710	710	710	
H2 Si 84/85 [mm]	585	585	630	780	780	780	
Weight Si 81/83 [kg]	27	28	36	52	63	68	
Weight Si 84/85 [kg]	29	30	39	60	68	74	
Inlet temperature	Max. set pressure [bar g]						Material code
-46 °C to -30 °C	18.3	18.3	48.0	96.0	144.0	189.6	22 LCB
-29 °C to 38 °C	19.7	19.7	51.0	102.0	153.1	189.6	00 WCB
39 °C to 232 °C	12.8	19.7	42.4	85.2	127.2	189.6	
233 °C to 427 °C	5.5	19.7	28.3	56.9	85.2	142.0	01 WC6
233 °C to 427 °C			35.2	70.0	105.1	175.1	04 CF8M
428 °C to 538 °C			14.8	29.6	44.8	74.5	
-268 °C to -60 °C	19.0	19.0	49.6	99.3	102.4	110.3	
-59 °C to -30 °C	19.0	19.0	49.6	99.3	148.9	189.6	
-29 °C to 38 °C	19.0	19.0	49.6	99.3	148.9	189.6	
39 °C to 232 °C	12.4	19.0	34.1	67.2	102.4	171.0	
233 °C to 427 °C	5.5	19.0	29.0	58.3	87.2	145.5	
428 °C to 538 °C	1.4	19.0	24.1	48.3	72.4	120.7	
Outlet temperature	Max. outlet pressure [bar g]						
Si 81/83@38 °C	18.3	18.3	18.3	18.3	18.3	47.9	22
Si 81/83@38 °C	19.7	19.7	19.7	19.7	19.7	51.0	00/01
Si 81/83@38 °C	19.0	19.0	19.0	19.0	19.0	41.4	04
Si 84/85@38 °C	15.9	15.9	15.9	15.9	15.9	28.6	all

Orifice H

Selection chart

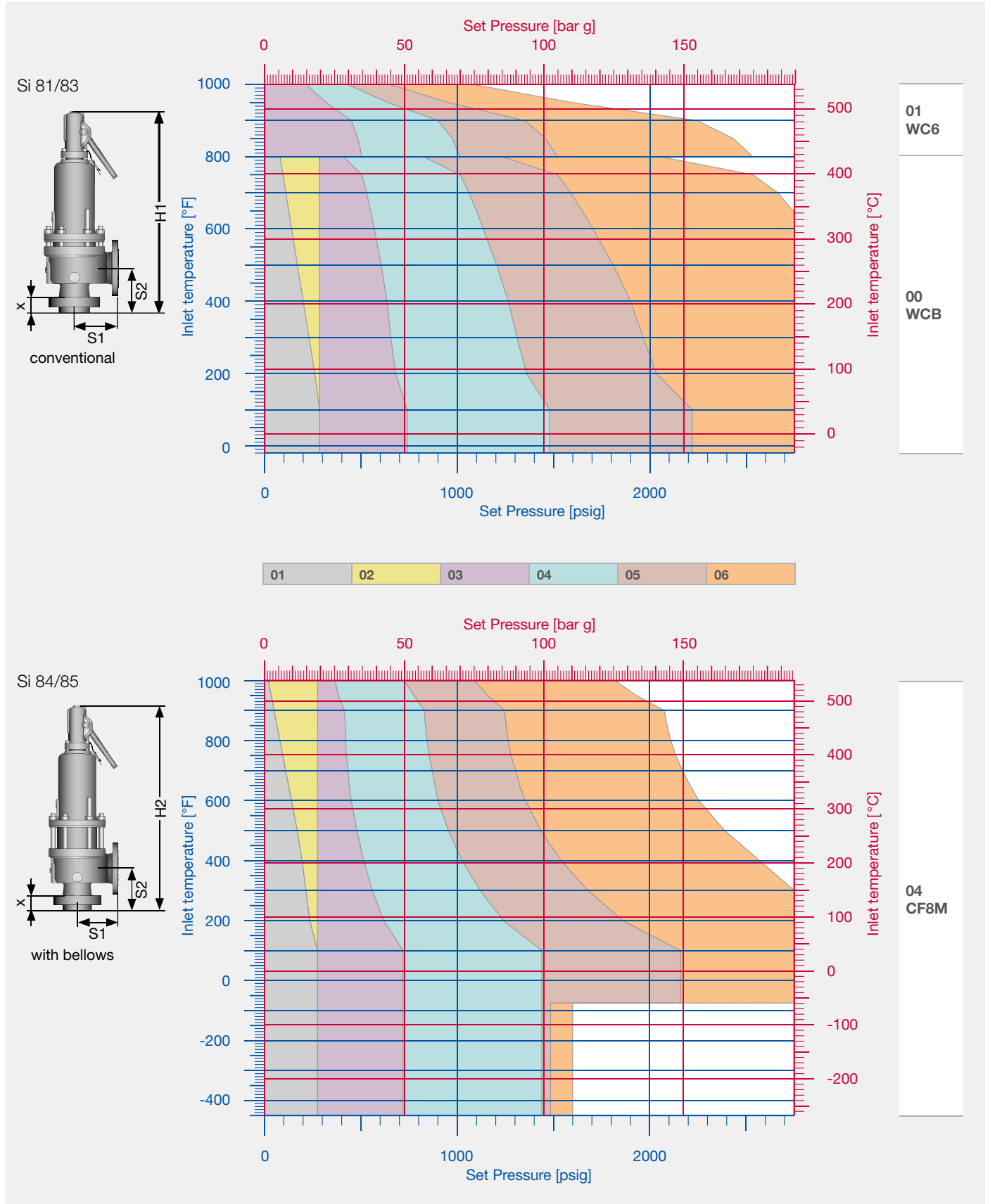

Orifice J

Minimum set pressures

Si 830x.57	3	psig	0.14	bar g
Si 830x	8	psig	0.5	bar g
Si 840x	21	psig	1.4	bar g

Effective area 1.287 in² / 830 mm²

Inlet class	01	02	03	04	05	06	
Class	150 x 150	300 x 150	300 x 150	600 x 150	900 x 150	1500 x 300	
NPS Inlet x outlet	2" x 3"	2" x 3"	3" x 4"	3" x 4"	3" x 4"	3" x 4"	
S1 [in]	4.87	4.87	7.13	7.13	7.13	7.13	
S2 [in]	5.37	5.37	7.25	7.25	7.25	7.25	
X [in]	1.57	1.57	2.64	2.64	3.23	3.23	
H1 Si 81/83 [in]	22.64	22.64	29.13	29.53	32.68	32.68	
H2 Si 84/85 [in]	24.80	24.80	31.89	31.89	35.63	35.63	
Weight Si 81/83 [lbs]	69	73	102	117	155	166	
Weight Si 84/85 [lbs]	78	82	111	128	170	181	
Inlet temperature	Max. set pressure [psig]						Material code
-51 °F to -21 °F	266	266	696	1392	2089	2700	22 LCB
-20 °F to 100 °F	285	285	740	1480	2220	2700	00 WCB
101 °F to 450 °F	185	285	615	1235	1845	2700	
451 °F to 800 °F	80	285	410	825	1235	2060	01 WC6
451 °F to 800 °F			510	1015	1525	2540	
801 °F to 1000 °F			215	430	650	1080	04 CF8M
-450 °F to -76 °F	275	275	500	625	800	800	
-75 °F to -21 °F	275	275	720	1440	2160	2750	
-20 °F to -100 °F	275	275	720	1440	2160	2750	
101 °F to 450 °F	180	275	495	975	1485	2480	
451 °F to 800 °F	80	275	420	845	1265	2110	
801 °F to 1000 °F	20	275	350	700	1050	1750	
Outlet temperature	Max. outlet pressure [psig]						
Si 81/83@100 °F	265	265	265	265	265	600	22
Si 81/83@100 °F	285	285	285	285	285	600	00/01
Si 81/83@100 °F	275	275	275	275	275	600	04
Si 84/85@100 °F	230	230	230	230	230	230	all

Inlet class	01	02	03	04	05	06	
Class	150 x 150	300 x 150	300 x 150	600 x 150	900 x 150	1500 x 300	
NPS Inlet x outlet	2" x 3"	2" x 3"	3" x 4"	3" x 4"	3" x 4"	3" x 4"	
S1 [mm]	123.8	123.8	181.0	181.0	181.0	181.0	
S2 [mm]	136.5	136.5	184.2	184.2	184.2	184.2	
X [mm]	40	40	67	67	82	82	
H1 Si 81/83 [mm]	575	575	740	750	830	830	
H2 Si 84/85 [mm]	630	630	810	810	905	905	
Weight Si 81/83 [kg]	31	33	46	53	70	75	
Weight Si 84/85 [kg]	35	37	50	58	77	82	
Inlet temperature	Max. set pressure [bar g]						Material code
-46 °C to -30 °C	18.3	18.3	48.0	96.0	144.0	186.2	22 LCB
-29 °C to 38 °C	19.7	19.7	51.0	102.0	153.1	186.2	00 WCB
39 °C to 232 °C	12.8	19.7	42.4	85.2	127.2	186.2	
233 °C to 427 °C	5.5	19.7	28.3	56.9	85.2	142.0	01 WC6
233 °C to 427 °C			35.2	70.0	105.1	175.1	
428 °C to 538 °C			14.8	29.6	44.8	74.5	04 CF8M
-268 °C to -60 °C	19.0	19.0	34.5	43.1	55.2	55.2	
-59 °C to -30 °C	19.0	19.0	49.6	99.3	148.9	189.6	
-29 °C to 38 °C	19.0	19.0	49.6	99.3	148.9	189.6	
39 °C to 232 °C	12.4	19.0	34.1	67.2	102.4	171.0	
233 °C to 427 °C	5.5	19.0	29.0	58.3	87.2	145.5	
428 °C to 538 °C	1.4	19.0	24.1	48.3	72.4	120.7	
Outlet temperature	Max. outlet pressure [bar g]						
Si 81/83@38 °C	18.3	18.3	18.3	18.3	18.3	41.4	22
Si 81/83@38 °C	19.7	19.7	19.7	19.7	19.7	41.4	00/01
Si 81/83@38 °C	19.0	19.0	19.0	19.0	19.0	41.4	04
Si 84/85@38 °C	15.9	15.9	15.9	15.9	15.9	15.9	all

Orifice J

Selection chart

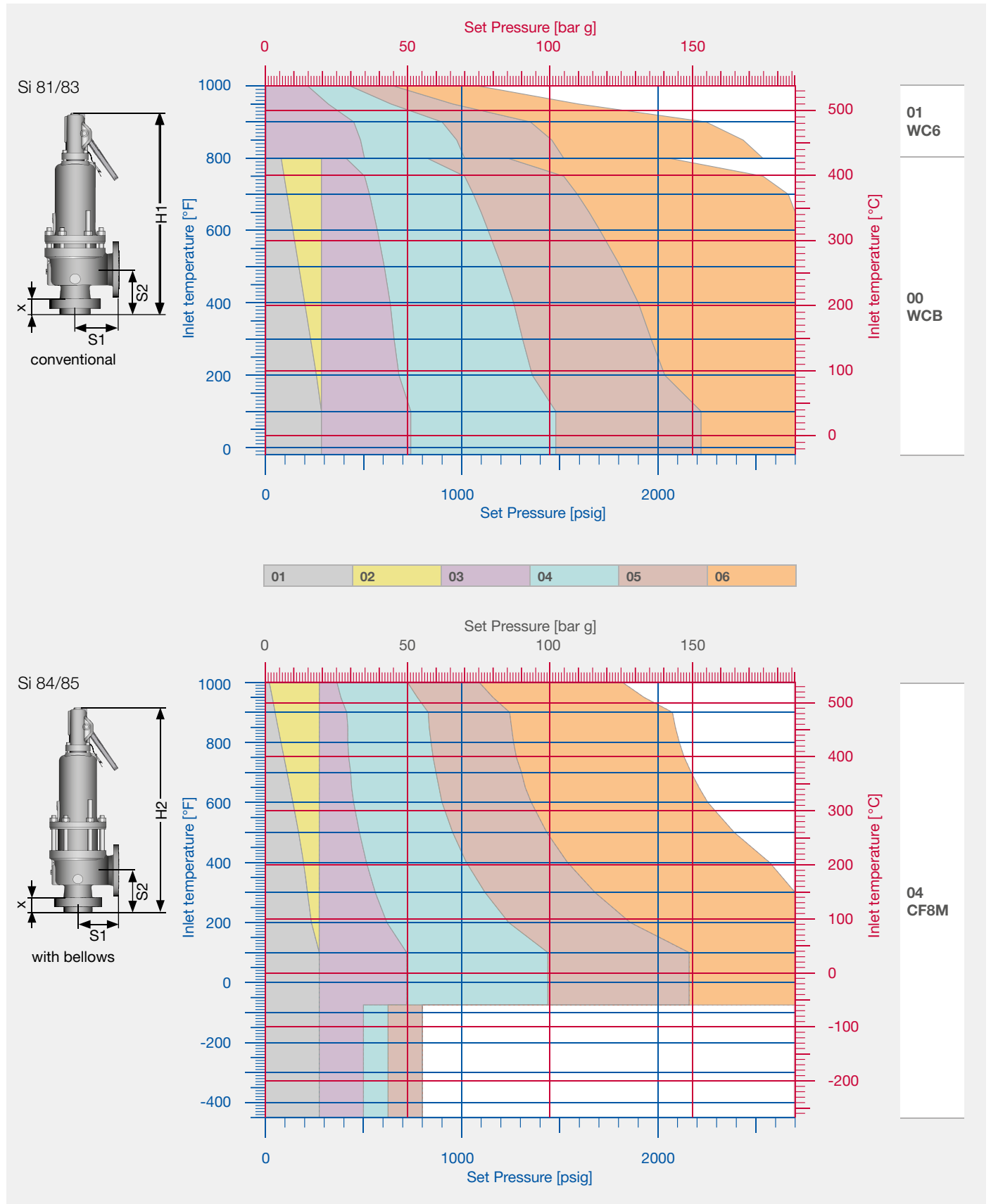

Orifice K

Minimum set pressures

Si 830x.57	3	psig	0.18	bar g
Si 830x	8	psig	0.5	bar g
Si 840x	22	psig	1.5	bar g

Effective area 1.838 in² / 1185 mm²

Inlet class	01	02	03	04	04	05	06	
Class	150 x 150	300 x 150	300 x 150	600 x 150	600 x 150	900 x 150	1500 x 300	
NPS Inlet x outlet	3" x 4"	3" x 4"	3" x 4"	3" x 4"	3" x 4"	3" x 6"	3" x 6"	
S1 [in]	6.37	6.37	6.37	6.37	7.13	8.50	8.50	
S2 [in]	6.13	6.13	6.13	6.13	7.25	7.81	7.75	
X [in]	2.32	2.32	2.32	2.32	2.64	2.99	2.99	
H1 Si 81/83 [in]	28.35	28.35	28.35	28.35	32.68	38.98	38.98	
H2 Si 84/85 [in]	31.10	31.10	31.10	31.10	35.83	42.32	42.32	
Weight Si 81/83 [lbs]	137	144	144	144	164	177	188	
Weight Si 84/85 [lbs]	148	157	157	157	172	199	210	
Inlet temperature	Max. set pressure [psig]							Material code
-51 °F to -21 °F	266	266	696		1392	2089	2220	22 LCB
-20 °F to 100 °F	285	285	740		1480	2220	2220	
101 °F to 450 °F	185	285	615		1235	1845	2220	00 WCB
451 °F to 800 °F	80	285	410		825	1235	2060	
451 °F to 800 °F			510	1015		1525	2220	01 WC6
801 °F to 1000 °F			215	430		650	1080	
-450 °F to -76 °F	275	275	525		600	600	750	
-75 °F to -21 °F	275	275	720		1440	2160	2220	
-20 °F to -100 °F	275	275	720		1440	2160	2220	04 CF8M
101 °F to 450 °F	180	275	495		975	1485	2220	
451 °F to 800 °F	80	275	420		845	1265	2110	
801 °F to 1000 °F	20	275	350		700	1050	1750	
Outlet temperature	Max. outlet pressure [psig]							
Si 81/83@100 °F	265	265	265		265	265	600	22
Si 81/83@100 °F	285	285	285	285	285	285	600	00/01
Si 81/83@100 °F	275	275	275		275	275	600	04
Si 84/85@100 °F	150 (230)	150 (230)	150 (230)	200 (230)	200 (230)	200 (230)	200 (230)	00/22 (01/04)

Inlet class	01	02	03	04	04	05	06	
Class	150 x 150	300 x 150	300 x 150	600 x 150	600 x 150	900 x 150	1500 x 300	
NPS Inlet x outlet	3" x 4"	3" x 4"	3" x 4"	3" x 4"	3" x 4"	3" x 6"	3" x 6"	
S1 [mm]	161.9	161.9	161.9	161.9	181.0	215.9	215.9	
S2 [mm]	155.6	155.6	155.6	155.6	184.2	198.4	196.9	
X [mm]	59	59	59	59	67	76	76	
H1 Si 81/83 [mm]	720	720	720	720	830	990	990	
H2 Si 84/85 [mm]	790	790	790	790	910	1075	1075	
Weight Si 81/83 [kg]	62	65	65	65	74	80	85	
Weight Si 84/85 [kg]	67	71	71	71	78	90	95	
Inlet temperature	Max. set pressure [bar g]							Material code
-46 °C to -30 °C	18.3	18.3	48.0		96.0	144.0	153.1	22 LCB
-29 °C to 38 °C	19.7	19.7	51.0		102.0	153.1	153.1	
39 °C to 232 °C	12.8	19.7	42.4		85.2	127.2	153.1	00 WCB
233 °C to 427 °C	5.5	19.7	28.3		56.9	85.2	142.0	
233 °C to 427 °C			35.2	70.0		105.1	153.1	01 WC6
428 °C to 538 °C			14.8	29.6		44.8	74.5	
-268 °C to -60 °C	19.0	19.0	36.2		41.4	41.4	51.7	
-59 °C to -30 °C	19.0	19.0	49.6		99.3	148.9	153.1	
-29 °C to 38 °C	19.0	19.0	49.6		99.3	148.9	153.1	04 CF8M
39 °C to 232 °C	12.4	19.0	34.1		67.2	102.4	153.1	
233 °C to 427 °C	5.5	19.0	29.0		58.3	87.2	145.5	
428 °C to 538 °C	1.4	19.0	24.1		48.3	72.4	120.7	
Outlet temperature	Max. outlet pressure [bar g]							
Si 81/83@38 °C	18.3	18.3	18.3		18.3	18.3	41.4	22
Si 81/83@38 °C	19.7	19.7	19.7	19.7	19.7	19.7	41.4	00/01
Si 81/83@38 °C	19.0	19.0	19.0		19.0	19.0	41.4	04
Si 84/85@38 °C	10.3 (15.9)	10.3 (15.9)	10.3 (15.9)	13.8 (15.9)	13.8 (15.9)	13.8 (15.9)	13.8 (15.9)	00/22 (01/04)

Orifice K

Selection chart

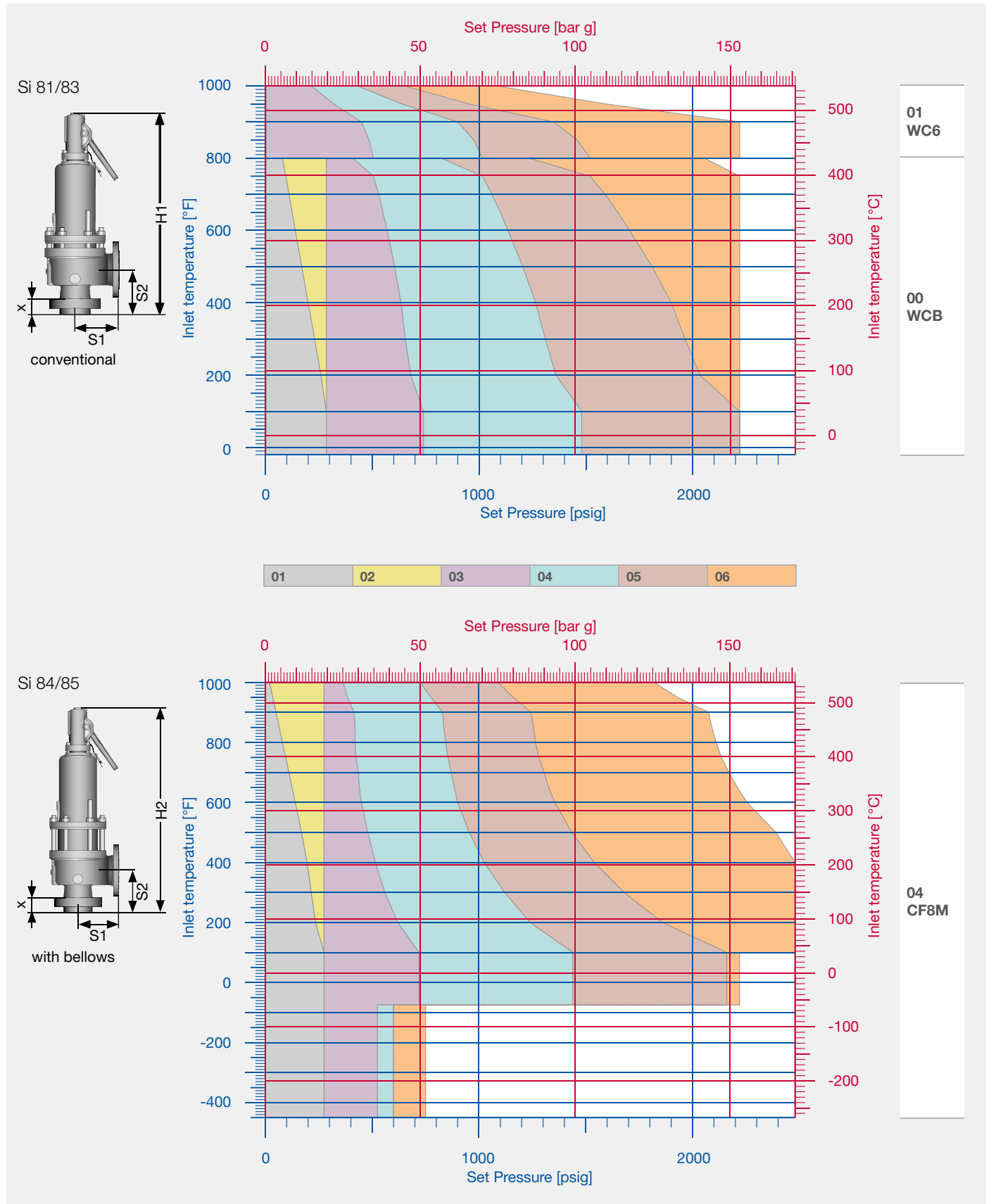

Orifice L

Minimum set pressures

Si 830x.57	3	psig	0.14	bar g
Si 830x	8	psig	0.5	bar g
Si 840x	15	psig	1	bar g

Effective area 2.853 in² / 1840 mm²

Inlet class	01	02	03	04	05	06	
Class	150 x 150	300 x 150	300 x 150	600 x 150	900 x 150	1500 x 150	
NPS Inlet x outlet	3" x 4"	3" x 4"	4" x 6"	4" x 6"	4" x 6"	4" x 6"	
S1 [in]	6.50	6.50	7.13	8.00	8.75	8.75	
S2 [in]	6.13	6.13	7.06	7.06	7.75	7.75	
X [in]	2.32	2.32	2.32	2.36	3.23	3.23	
H1 Si 81/83 [in]	28.35	28.35	33.46	38.78	38.78	38.78	
H2 Si 84/85 [in]	31.10	31.10	36.61	42.52	42.52	42.52	
Weight Si 81/83 [lbs]	137	144	221	232	336	353	
Weight Si 84/85 [lbs]	148	155	221	265	362	371	
Inlet temperature	Max. set pressure [psig]						Material code
-51 °F to -21 °F	266	266	696	1000	700		22 LCB
-20 °F to 100 °F	285	285	740	1000	1500	1500	00 WCB
101 °F to 450 °F	185	285	615	1000	1500	1500	
451 °F to 800 °F	80	285	410	825	1235	1500	01 WC6
451 °F to 800 °F			510	1000	1500	1500	
801 °F to 1000 °F			215	430	650	1080	04 CF8M
-450 °F to -76 °F	275	275	535	535	700		
-75 °F to -21 °F	275	275	720	1000	1500		
-20 °F to -100 °F	275	275	720	1000	1500		
101 °F to 450 °F	180	275	495	975	1485		
451 °F to 800 °F	80	275	420	845	1265		
801 °F to 1000 °F	20	275	350	700	1050		
Outlet temperature	Max. outlet pressure [psig]						
Si 81/83@100 °F	265	265	265	265	265		22
Si 81/83@100 °F	285	285	285	285	285	285	00/01
Si 81/83@100 °F	275	275	275	275	275		04
Si 84/85@100 °F	100	100	170	170	170	170	all

Inlet class	01	02	03	04	05	06	
Class	150 x 150	300 x 150	300 x 150	600 x 150	900 x 150	1500 x 150	
NPS Inlet x outlet	3" x 4"	3" x 4"	4" x 6"	4" x 6"	4" x 6"	4" x 6"	
S1 [mm]	165.1	165.1	181.0	203.2	222.3	222.3	
S2 [mm]	155.6	155.6	179.4	179.4	196.9	196.9	
X [mm]	59	59	59	60	82	82	
H1 Si 81/83 [mm]	720	720	850	985	985	985	
H2 Si 84/85 [mm]	790	790	930	1080	1080	1080	
Weight Si 81/83 [kg]	62	65	100	105	152	160	
Weight Si 84/85 [kg]	67	70	100	120	164	168	
Inlet temperature	Max. set pressure [bar g]						Material code
-46 °C to -30 °C	18.3	18.3	48.0	68.9	103.4		22 LCB
-29 °C to 38 °C	19.7	19.7	51.0	68.9	103.4	103.4	00 WCB
39 °C to 232 °C	12.8	19.7	42.4	68.9	103.4	103.4	
233 °C to 427 °C	5.5	19.7	28.3	56.9	85.2	103.4	01 WC6
233 °C to 427 °C			35.2	68.9	103.4	103.4	
428 °C to 538 °C			14.8	29.6	44.8	74.5	04 CF8M
-268 °C to -60 °C	19.0	19.0	36.9	36.9	48.3		
-59 °C to -30 °C	19.0	19.0	49.6	68.9	103.4		
-29 °C to 38 °C	19.0	19.0	49.6	68.9	103.4		
39 °C to 232 °C	12.4	19.0	34.1	67.2	102.4		
233 °C to 427 °C	5.5	19.0	29.0	58.3	87.2		
428 °C to 538 °C	1.4	19.0	24.1	48.3	72.4		
Outlet temperature	Max. outlet pressure [bar g]						
Si 81/83@38 °C	18.3	18.3	18.3	18.3	18.3		22
Si 81/83@38 °C	19.7	19.7	19.7	19.7	19.7	19.7	00/01
Si 81/83@38 °C	19.0	19.0	19.0	19.0	19.0		04
Si 84/85@38 °C	6.9	6.9	11.7	11.7	11.7	11.7	all

Orifice L

Selection chart

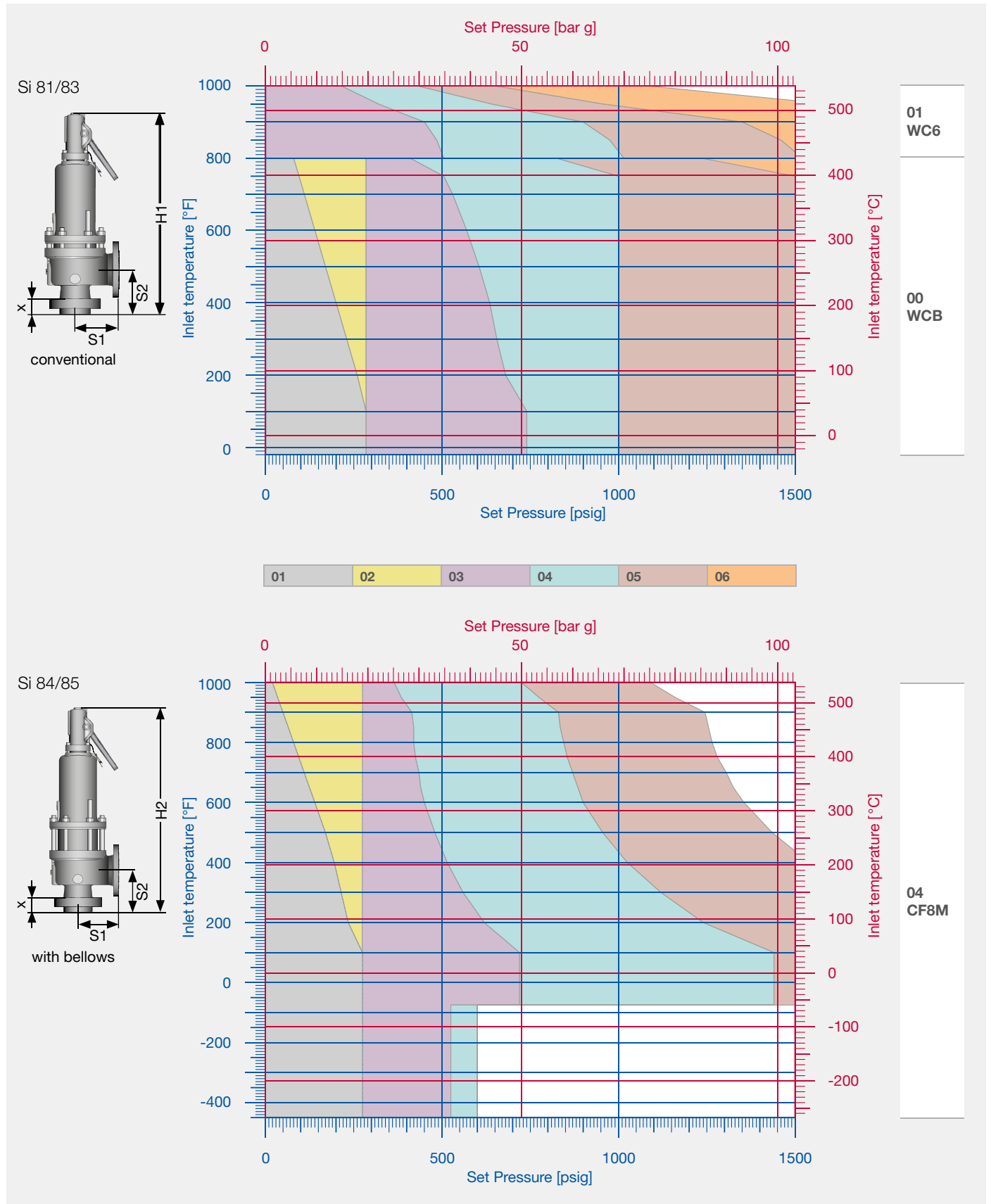

Orifice M

Minimum set pressures

Si 830x.57	3	psig	0.17	bar g
Si 830x	8	psig	0.5	bar g
Si 840x	18	psig	1.2	bar g

Effective area 3.60 in² / 2322 mm²

Inlet class	01	02	03	04	05	
Class	150 x 150	300 x 150	300 x 150	600 x 150	900 x 150	
NPS Inlet x outlet	4" x 6"	4" x 6"	4" x 6"	4" x 6"	4" x 6"	
S1 [in]	7.25	7.25	7.25	8.00	8.75	
S2 [in]	7.00	7.00	7.00	7.00	7.75	
X [in]	2.20	2.20	2.20	2.44	3.23	
H1 Si 81/83 [in]	33.46	33.46	33.46	38.78	39.57	
H2 Si 84/85 [in]	36.42	36.42	36.42	41.14	41.73	
Weight Si 81/83 [lbs]	212	221	221	336	353	
Weight Si 84/85 [lbs]	239	247	247	362	375	
Inlet temperature	Max. set pressure [psig]					Material code
-51 °F to -21 °F	266	266	696	1000		22 LCB
-20 °F to 100 °F	285	285	740	1100	1100	
101 °F to 450 °F	185	285	615	1100	1100	00 WCB
451 °F to 800 °F	80	285	410	825	1100	
451 °F to 800 °F			510	1000	1100	01 WC6
801 °F to 1000 °F			215	430	650	
-450 °F to -76 °F	275	275	525	600		
-75 °F to -21 °F	275	275	720	1100		
-20 °F to -100 °F	275	275	720	1100		04 CF8M
101 °F to 450 °F	180	275	495	975		
451 °F to 800 °F	80	275	420	845		
801 °F to 1000 °F	20	275	350	700		
Outlet temperature	Max. outlet pressure [psig]					
Si 81/83@100 °F	265	265	265	265		22
Si 81/83@100 °F	285	285	285	285	285	00/01
Si 81/83@100 °F	275	275	275	275		04
Si 84/85@100 °F	80	80	160	160	160	all

Inlet class	01	02	03	04	05	
Class	150 x 150	300 x 150	300 x 150	600 x 150	900 x 150	
NPS Inlet x outlet	4" x 6"	4" x 6"	4" x 6"	4" x 6"	4" x 6"	
S1 [mm]	184.2	184.2	184.2	203.2	222.3	
S2 [mm]	177.8	177.8	177.8	177.8	196.9	
X [mm]	56	56	56	62	82	
H1 Si 81/83 [mm]	850	850	850	985	1005	
H2 Si 84/85 [mm]	925	925	925	1045	1060	
Weight Si 81/83 [kg]	96	100	100	152	160	
Weight Si 84/85 [kg]	108	112	112	164	170	
Inlet temperature	Max. set pressure [bar g]					Material code
-46 °C to -30 °C	18.3	18.3	48.0	68.9		22 LCB
-29 °C to 38 °C	19.7	19.7	51.0	75.8	75.8	
39 °C to 232 °C	12.8	19.7	42.4	75.8	75.8	00 WCB
233 °C to 427 °C	5.5	19.7	28.3	56.9	75.8	
233 °C to 427 °C			35.2	68.9	75.8	01 WC6
428 °C to 538 °C			14.8	29.6	44.8	
-268 °C to -60 °C	19.0	19.0	36.2	41.4		
-59 °C to -30 °C	19.0	19.0	49.6	75.8		
-29 °C to 38 °C	19.0	19.0	49.6	75.8		04 CF8M
39 °C to 232 °C	12.4	19.0	34.1	67.2		
233 °C to 427 °C	5.5	19.0	29.0	58.3		
428 °C to 538 °C	1.4	19.0	24.1	48.3		
Outlet temperature	Max. outlet pressure [bar g]					
Si 81/83@38 °C	18.3	18.3	18.3	18.3		22
Si 81/83@38 °C	19.7	19.7	19.7	19.7	19.7	00/01
Si 81/83@38 °C	19.0	19.0	19.0	19.0		04
Si 84/85@38 °C	5.5	5.5	11.0	11.0	11.0	all

Orifice M

Selection chart

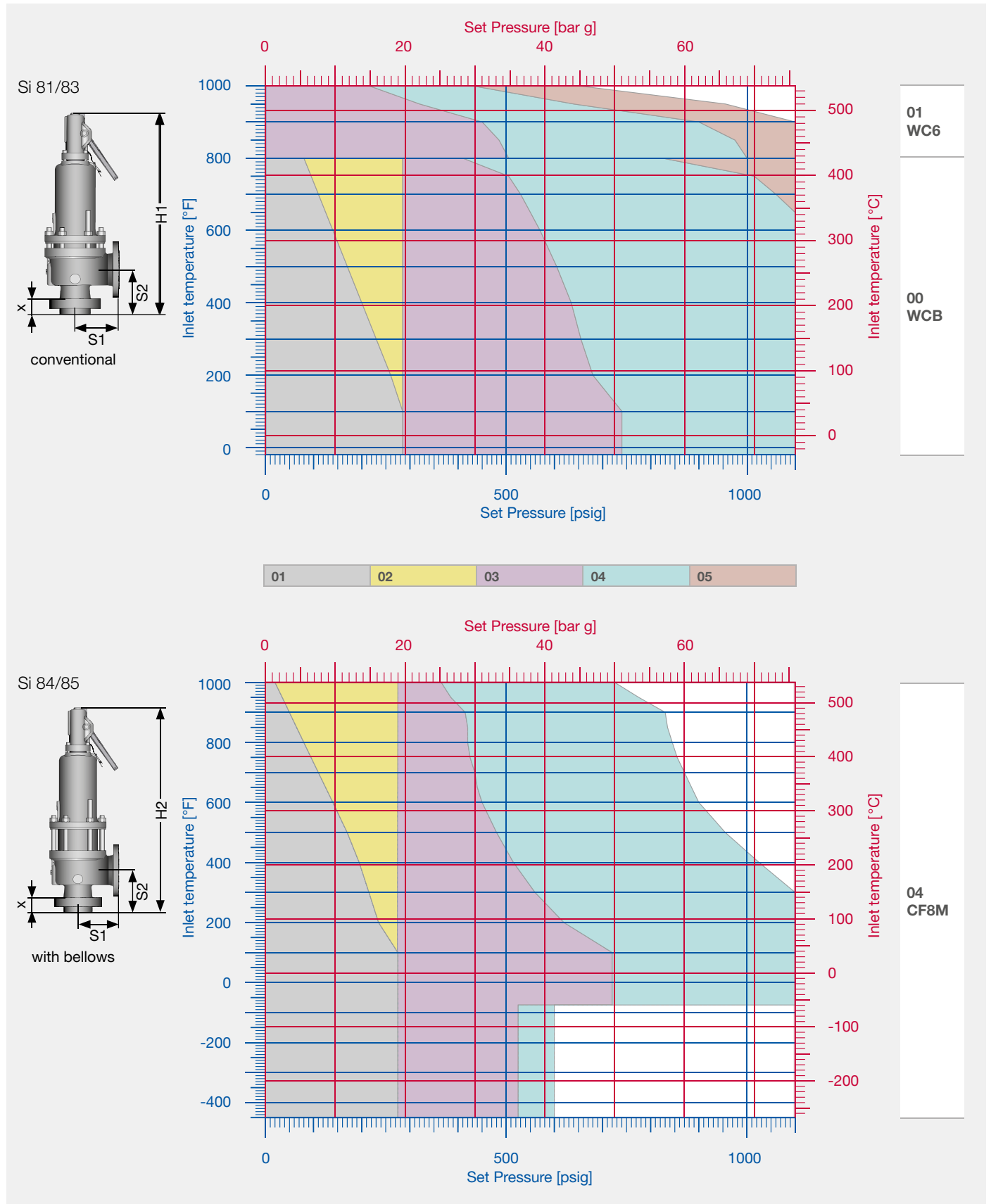

Orifice N

Minimum set pressures

Si 830x.57	4	psig	0.25	bar g
Si 830x	8	psig	0.5	bar g
Si 840x	16	psig	1.1	bar g

Effective area 3.60 in² / 2322 mm²

Inlet class	01	02	03	04	05	
Class	150 x 150	300 x 150	300 x 150	600 x 150	900 x 150	
NPS Inlet x outlet	4" x 6"	4" x 6"	4" x 6"	4" x 6"	4" x 6"	
S1 [in]	8.25	8.25	8.25	8.75	8.75	
S2 [in]	7.75	7.75	7.75	7.75	7.75	
X [in]	2.17	2.17	2.17	3.23	3.23	
H1 Si 81/83 [in]	38.98	38.98	38.98	38.98	38.98	
H2 Si 84/85 [in]	43.11	43.11	43.11	43.11	43.11	
Weight Si 81/83 [lbs]	305	316	316	349	355	
Weight Si 84/85 [lbs]	336	347	347	375	397	
Inlet temperature	Max. set pressure [psig]					Material code
-51 °F to -21 °F	266	266	696	1000		22 LCB
-20 °F to 100 °F	285	285	740	1000	1000	00 WCB
101 °F to 450 °F	185	285	615	1000	1000	
451 °F to 800 °F	80	285	410	825	1000	
451 °F to 800 °F			510	1000	1000	01 WC6
801 °F to 1000 °F			215	430	650	
-450 °F to -76 °F	275	275	450	500		04 CF8M
-75 °F to -21 °F	275	275	720	1000		
-20 °F to -100 °F	275	275	720	1000		
101 °F to 450 °F	180	275	495	975		
451 °F to 800 °F	80	275	420	845		
801 °F to 1000 °F	20	275	350	700		
Outlet temperature	Max. outlet pressure [psig]					
Si 81/83@100 °F	265	265	265	265		22
Si 81/83@100 °F	285	285	285	285	285	00/01
Si 81/83@100 °F	275	275	275	275		04
Si 84/85@100 °F	80	80	160	160	160	all

Inlet class	01	02	03	04	05	
Class	150 x 150	300 x 150	300 x 150	600 x 150	900 x 150	
NPS Inlet x outlet	4" x 6"	4" x 6"	4" x 6"	4" x 6"	4" x 6"	
S1 [mm]	209.6	209.6	209.6	222.3	222.3	
S2 [mm]	196.9	196.9	196.9	196.9	196.9	
X [mm]	55	55	55	82	82	
H1 Si 81/83 [mm]	990	990	990	990	990	
H2 Si 84/85 [mm]	1095	1095	1095	1095	1095	
Weight Si 81/83 [kg]	138	143	143	158	161	
Weight Si 84/85 [kg]	152	157	157	170	180	
Inlet temperature	Max. set pressure [bar g]					Material code
-46 °C to -30 °C	18.3	18.3	48.0	68.9		22 LCB
-29 °C to 38 °C	19.7	19.7	51.0	68.9	68.9	00 WCB
39 °C to 232 °C	12.8	19.7	42.4	68.9	68.9	
233 °C to 427 °C	5.5	19.7	28.3	56.9	68.9	
233 °C to 427 °C			35.2	68.9	68.9	01 WC6
428 °C to 538 °C			14.8	29.6	44.8	
-268 °C to -60 °C	19.0	19.0	31.0	34.5		04 CF8M
-59 °C to -30 °C	19.0	19.0	49.6	68.9		
-29 °C to 38 °C	19.0	19.0	49.6	75.8		
39 °C to 232 °C	12.4	19.0	34.1	67.2		
233 °C to 427 °C	5.5	19.0	29.0	58.3		
428 °C to 538 °C	1.4	19.0	24.1	48.3		
Outlet temperature	Max. outlet pressure [bar g]					
Si 81/83@38 °C	18.3	18.3	18.3	18.3		22
Si 81/83@38 °C	19.7	19.7	19.7	19.7	19.7	00/01
Si 81/83@38 °C	19.0	19.0	19.0	19.0		04
Si 84/85@38 °C	5.5	5.5	11.0	11.0	11.0	all

Orifice N

Selection chart

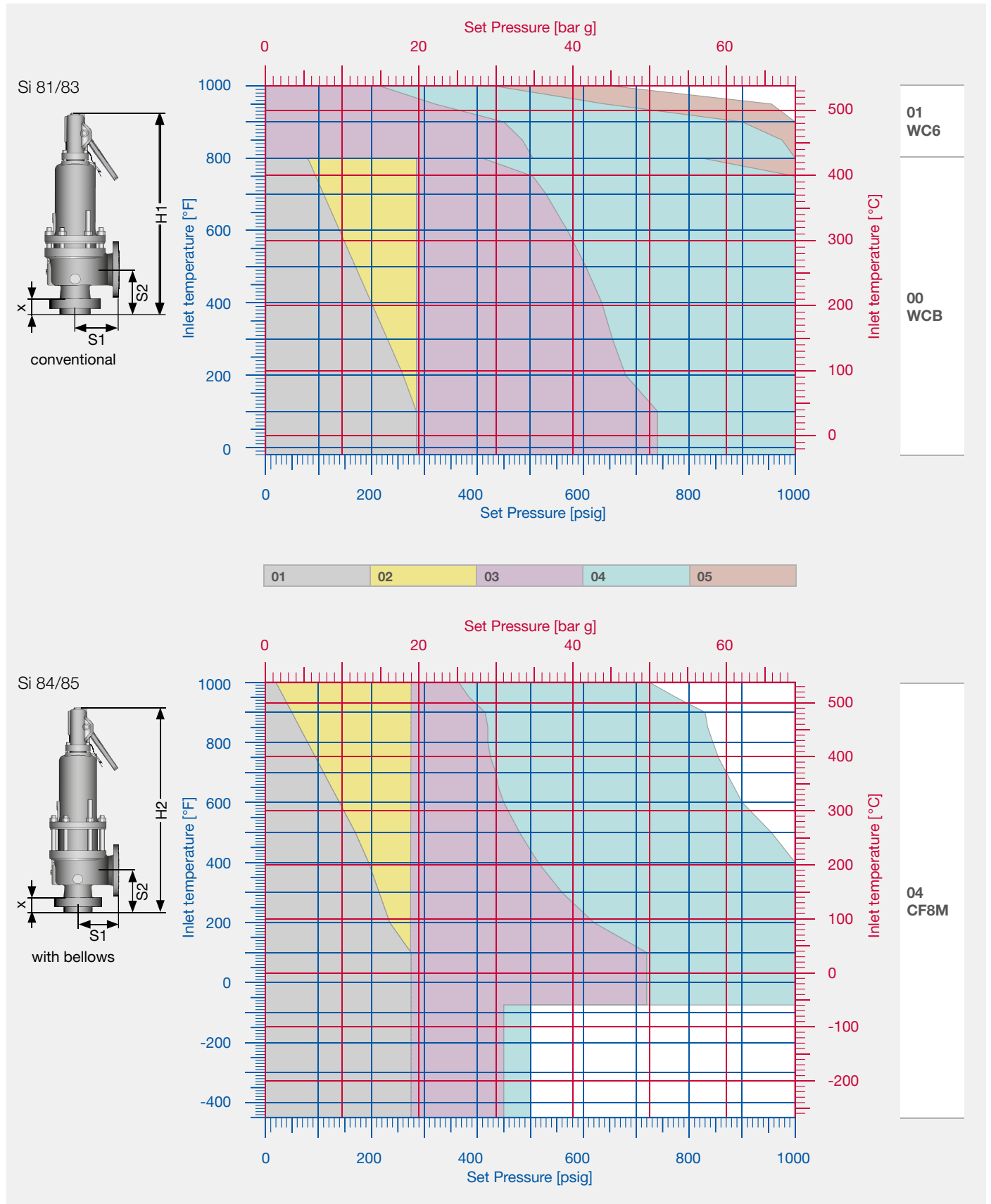

Orifice P

Minimum set pressures

Si 830x.57	4	psig	0.24	bar g
Si 830x	8	psig	0.5	bar g
Si 840x	15	psig	1	bar g

Effective area 6.38 in² / 4116 mm²

Inlet class	01	02	03	04	05	
Class	150 x 150	300 x 150	300 x 150	600 x 150	900 x 150	
NPS Inlet x outlet	4" x 6"	4" x 6"	4" x 6"	4" x 6"	4" x 6"	
S1 [in]	9.00	9.00	10.00	10.00	10.00	
S2 [in]	7.13	7.13	8.87	8.87	8.87	
X [in]	2.13	2.13	2.72	2.72	2.72	
H1 Si 81/83 [in]	38.58	38.58	46.06	46.06	46.06	
H2 Si 84/85 [in]	42.72	42.72	49.41	49.41	49.41	
Weight Si 81/83 [lbs]	314	325	386	393	530	
Weight Si 84/85 [lbs]	344	355	424	463	574	
Inlet temperature	Max. set pressure [psig]					Material code
-51 °F to -21 °F	266	266	525	1000		22 LCB
-20 °F to 100 °F	285	285	525	1000	1000	00 WCB
101 °F to 450 °F	185	285	525	1000	1000	
451 °F to 800 °F	80	285	410	825	1000	
451 °F to 800 °F			510	1000	1000	01 WC6
801 °F to 1000 °F			215	430	650	
-450 °F to -76 °F	175	175	300	480		04 CF8M
-75 °F to -21 °F	275	275	525	1000		
-20 °F to -100 °F	275	275	525	1000		
101 °F to 450 °F	180	275	495	975		
451 °F to 800 °F	80	275	420	845		
801 °F to 1000 °F	20	20	350	700		
Outlet temperature	Max. outlet pressure [psig]					
Si 81/83@100 °F	265	265	265	265		22
Si 81/83@100 °F	285	285	285	285	285	00/01
Si 81/83@100 °F	275	275	275	275		04
Si 84/85@100 °F	80	80	150 (160)	150 (160)	150 (160)	00/22 (01/04)

Inlet class	01	02	03	04	05	
Class	150 x 150	300 x 150	300 x 150	600 x 150	900 x 150	
NPS Inlet x outlet	4" x 6"	4" x 6"	4" x 6"	4" x 6"	4" x 6"	
S1 [mm]	228.6	228.6	254.0	254.0	254.0	
S2 [mm]	181.0	181.0	225.4	225.4	225.4	
X [mm]	54	54	69	69	69	
H1 Si 81/83 [mm]	980	980	1170	1170	1170	
H2 Si 84/85 [mm]	1085	1085	1255	1255	1255	
Weight Si 81/83 [kg]	142	147	175	178	240	
Weight Si 84/85 [kg]	156	161	192	210	260	
Inlet temperature	Max. set pressure [bar g]					Material code
-46 °C to -30 °C	18.3	18.3	36.2	68.9		22 LCB
-29 °C to 38 °C	19.7	19.7	36.2	68.9	68.9	00 WCB
39 °C to 232 °C	12.8	19.7	36.2	68.9	68.9	
233 °C to 427 °C	5.5	19.7	28.3	56.9	68.9	
233 °C to 427 °C			35.2	68.9	68.9	01 WC6
428 °C to 538 °C			14.8	29.6	44.8	
-268 °C to -60 °C	12.1	12.1	20.7	33.1		04 CF8M
-59 °C to -30 °C	19.0	19.0	36.2	68.9		
-29 °C to 38 °C	19.0	19.0	36.2	68.9		
39 °C to 232 °C	12.4	19.0	34.1	67.2		
233 °C to 427 °C	5.5	19.0	29.0	58.3		
428 °C to 538 °C	1.4	19.0	24.1	48.3		
Outlet temperature	Max. outlet pressure [bar g]					
Si 81/83@38 °C	18.3	18.3	18.3	18.3		22
Si 81/83@38 °C	19.7	19.7	19.7	19.7	19.7	00/01
Si 81/83@38 °C	19.0	19.0	19.0	19.0		04
Si 84/85@38 °C	5.5	5.5	10.3 (11.0)	10.3 (11.0)	10.3 (11.0)	00/22 (01/04)

Orifice P

Selection chart

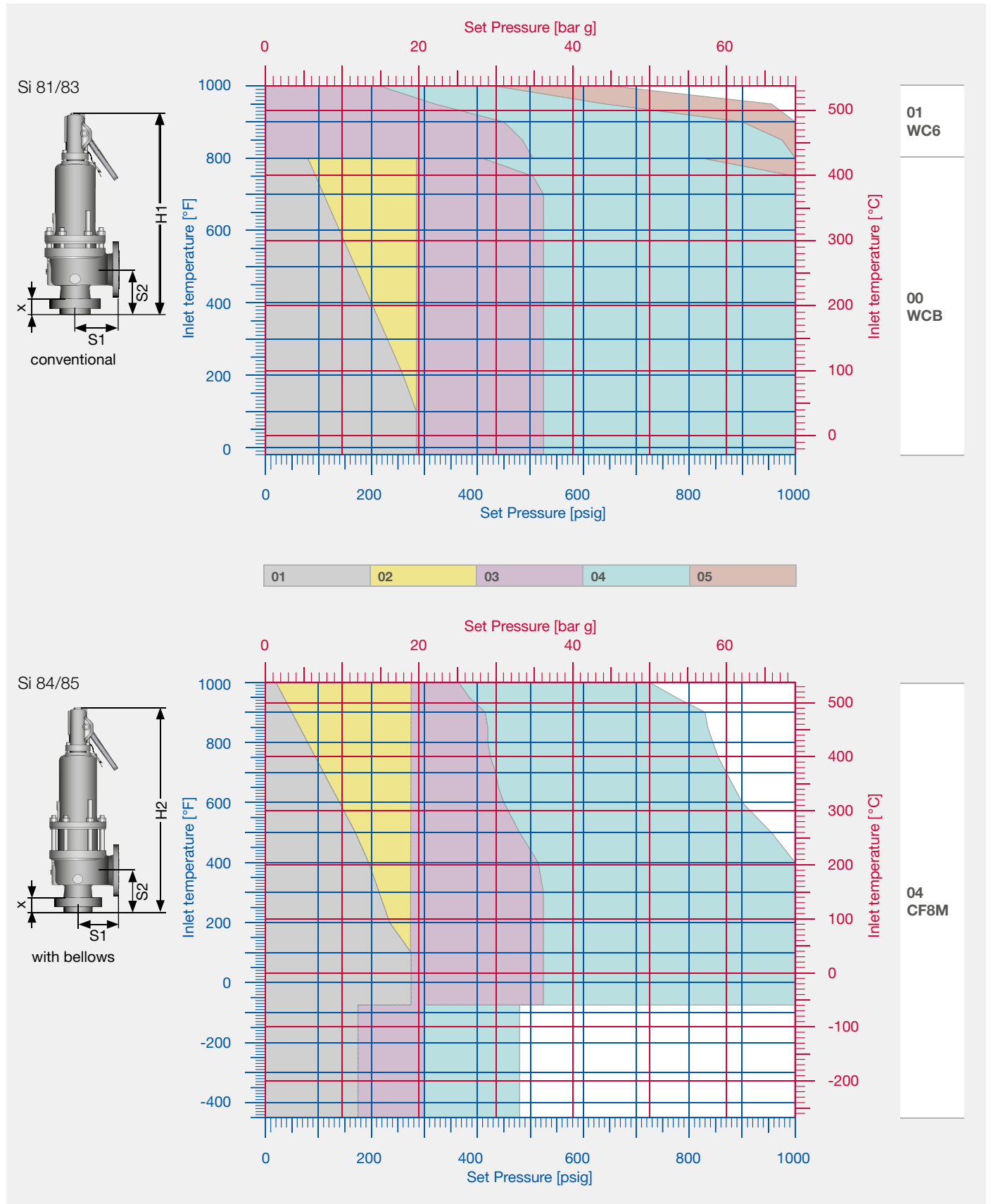

Orifice Q

Minimum set pressures

Si 830x.57	3	psig	0.18	bar g
Si 830x	8	psig	0.5	bar g
Si 840x	28	psig	1.9	bar g

Effective area 11.05 in² / 7129 mm²

Inlet class	01	02	03	04	
Class	150 x 150	300 x 150	300 x 150	600 x 150	
NPS Inlet x outlet	6" x 8"	6" x 8"	6" x 8"	6" x 8"	
S1 [in]	9.50	9.50	9.50	9.50	
S2 [in]	9.44	9.44	9.44	9.44	
X [in]	2.36	2.36	2.36	3.07	
H1 Si 81/83 [in]	46.26	46.26	46.26	46.85	
H2 Si 84/85 [in]	51.38	51.38	51.38	52.17	
Weight Si 81/83 [lbs]	463	486	486	640	
Weight Si 84/85 [lbs]	497	508	508	684	
Inlet temperature	Max. set pressure [psig]				Material code
-51 °F to -21 °F	165	165	300	600	22 LCB
-20 °F to 100 °F	165	165	300	600	
101 °F to 450 °F	165	165	300	600	00 WCB
451 °F to 800 °F	80	165	300	600	
451 °F to 800 °F			165	600	01 WC6
801 °F to 1000 °F			165	430	
-450 °F to -76 °F	165	165	250	300	
-75 °F to -21 °F	165	165	300	600	
-20 °F to -100 °F	165	165	300	600	04 CF8M
101 °F to 450 °F	165	165	300	600	
451 °F to 800 °F	80	165	300	600	
801 °F to 1000 °F	20	165	300	600	
Outlet temperature	Max. outlet pressure [psig]				
Si 81/83@100 °F	115	115	115	115	22
Si 81/83@100 °F	115	115	115	115	00/01
Si 81/83@100 °F	115	115	115	115	04
Si 84/85@100 °F	70	70	115	115	all

Inlet class	01	02	03	04	
Class	150 x 150	300 x 150	300 x 150	600 x 150	
NPS Inlet x outlet	6" x 8"	6" x 8"	6" x 8"	6" x 8"	
S1 [mm]	241.3	241.3	241.3	241.3	
S2 [mm]	239.7	239.7	239.7	239.7	
X [mm]	60	60	60	78	
H1 Si 81/83 [mm]	1175	1175	1175	1190	
H2 Si 84/85 [mm]	1305	1305	1305	1325	
Weight Si 81/83 [kg]	210	220	220	290	
Weight Si 84/85 [kg]	225	230	230	310	
Inlet temperature	Max. set pressure [bar g]				Material code
-46 °C to -30 °C	11.4	11.4	20.7	41.4	22 LCB
-29 °C to 38 °C	11.4	11.4	20.7	41.4	
39 °C to 232 °C	11.4	11.4	20.7	41.4	00 WCB
233 °C to 427 °C	5.5	11.4	20.7	41.4	
233 °C to 427 °C			11.4	41.4	01 WC6
428 °C to 538 °C			11.4	29.6	
-268 °C to -60 °C	11.4	11.4	17.2	20.7	
-59 °C to -30 °C	11.4	11.4	20.7	41.4	
-29 °C to 38 °C	11.4	11.4	20.7	41.4	04 CF8M
39 °C to 232 °C	11.4	11.4	20.7	41.4	
233 °C to 427 °C	5.5	11.4	20.7	41.4	
428 °C to 538 °C	1.4	11.4	20.7	41.4	
Outlet temperature	Max. outlet pressure [bar g]				
Si 81/83@38 °C	7.9	7.9	7.9	7.9	22
Si 81/83@38 °C	7.9	7.9	7.9	7.9	00/01
Si 81/83@38 °C	7.9	7.9	7.9	7.9	04
Si 84/85@38 °C	4.8	4.8	7.9	7.9	all

Orifice Q

Selection chart

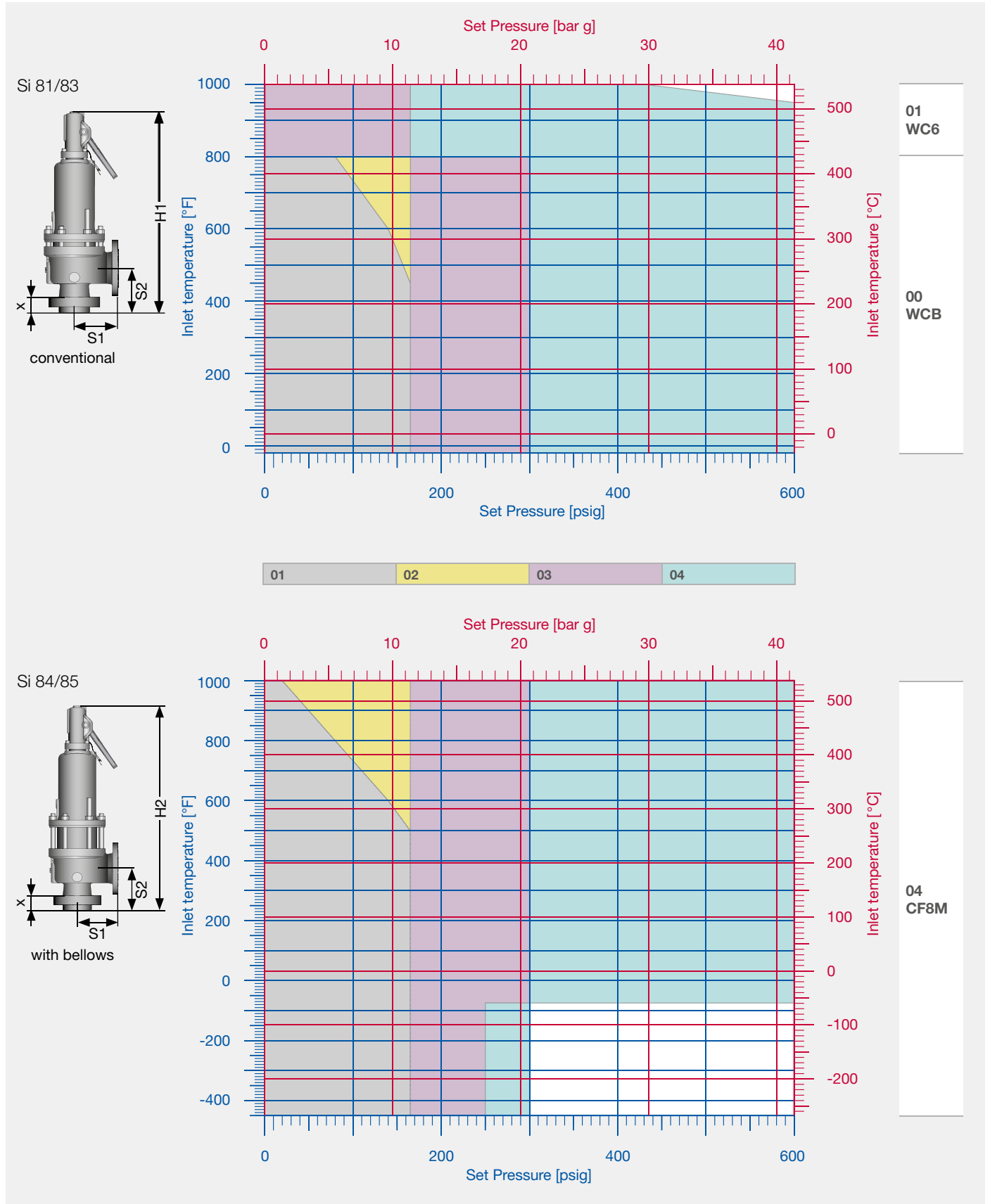

Orifice R

Minimum set pressures

Si 830x.57	3	psig	0.16	bar g
Si 830x	8	psig	0.5	bar g
Si 840x	29	psig	2	bar g

Effective area 16.00 in² / 10322 mm²

Inlet class	01	02	03	04	
Class	150 x 150	300 x 150	300 x 150	600 x 150	
NPS Inlet x outlet	6" x 8"	6" x 8"	6" x 10"	6" x 10"	
S1 [in]	9.50	9.50	10.50	10.50	
S2 [in]	9.44	9.44	9.44	9.44	
X [in]	2.36	2.36	2.99	2.99	
H1 Si 81/83 [in]	46.26	46.26	48.82	48.82	
H2 Si 84/85 [in]	51.38	51.38	55.71	55.71	
Weight Si 81/83 [lbs]	470	492	631	662	
Weight Si 84/85 [lbs]	503	530	735	757	
Inlet temperature	Max. set pressure [psig]				Material code
-51 °F to -21 °F	100	100	230	300	22 LCB
-20 °F to 100 °F	100	100	230	300	
101 °F to 450 °F	100	100	230	300	00 WCB
451 °F to 800 °F	80	100	230	300	
451 °F to 800 °F		100		300	01 WC6
801 °F to 1000 °F		100		300	
-450 °F to -76 °F	55	55	150	200	
-75 °F to -21 °F	100	100	230	300	
-20 °F to -100 °F	100	100	230	300	04 CF8M
101 °F to 450 °F	100	100	230	300	
451 °F to 800 °F	80	100	230	300	
801 °F to 1000 °F	20	100	230	300	
Outlet temperature	Max. outlet pressure [psig]				
Si 81/83@100 °F	60	60	100	100	22
Si 81/83@100 °F	60	60	100	100	00/01
Si 81/83@100 °F	60	60	100	100	04
Si 84/85@100 °F	60	60	100	100	all

Inlet class	01	02	03	04	
Class	150 x 150	300 x 150	300 x 150	600 x 150	
NPS Inlet x outlet	6" x 8"	6" x 8"	6" x 10"	6" x 10"	
S1 [mm]	241.3	241.3	266.7	266.7	
S2 [mm]	239.7	239.7	239.7	239.7	
X [mm]	60	60	76	76	
H1 Si 81/83 [mm]	1175	1175	1240	1240	
H2 Si 84/85 [mm]	1305	1305	1415	1415	
Weight Si 81/83 [kg]	213	223	286	300	
Weight Si 84/85 [kg]	228	240	333	343	
Inlet temperature	Max. set pressure [bar g]				Material code
-46 °C to -30 °C	6.9	6.9	15.9	20.7	22 LCB
-29 °C to 38 °C	6.9	6.9	15.9	20.7	
39 °C to 232 °C	6.9	6.9	15.9	20.7	00 WCB
233 °C to 427 °C	5.5	6.9	15.9	20.7	
233 °C to 427 °C		6.9		20.7	01 WC6
428 °C to 538 °C		6.9		20.7	
-268 °C to -60 °C	3.8	3.8	10.3	13.8	
-59 °C to -30 °C	6.9	6.9	15.9	20.7	
-29 °C to 38 °C	6.9	6.9	15.9	20.7	04 CF8M
39 °C to 232 °C	6.9	6.9	15.9	20.7	
233 °C to 427 °C	5.5	6.9	15.9	20.7	
428 °C to 538 °C	1.4	6.9	15.9	20.7	
Outlet temperature	Max. outlet pressure [bar g]				
Si 81/83@38 °C	4.1	4.1	6.9	6.9	22
Si 81/83@38 °C	4.1	4.1	6.9	6.9	00/01
Si 81/83@38 °C	4.1	4.1	6.9	6.9	04
Si 84/85@38 °C	4.1	4.1	6.9	6.9	all

Orifice R

Selection chart

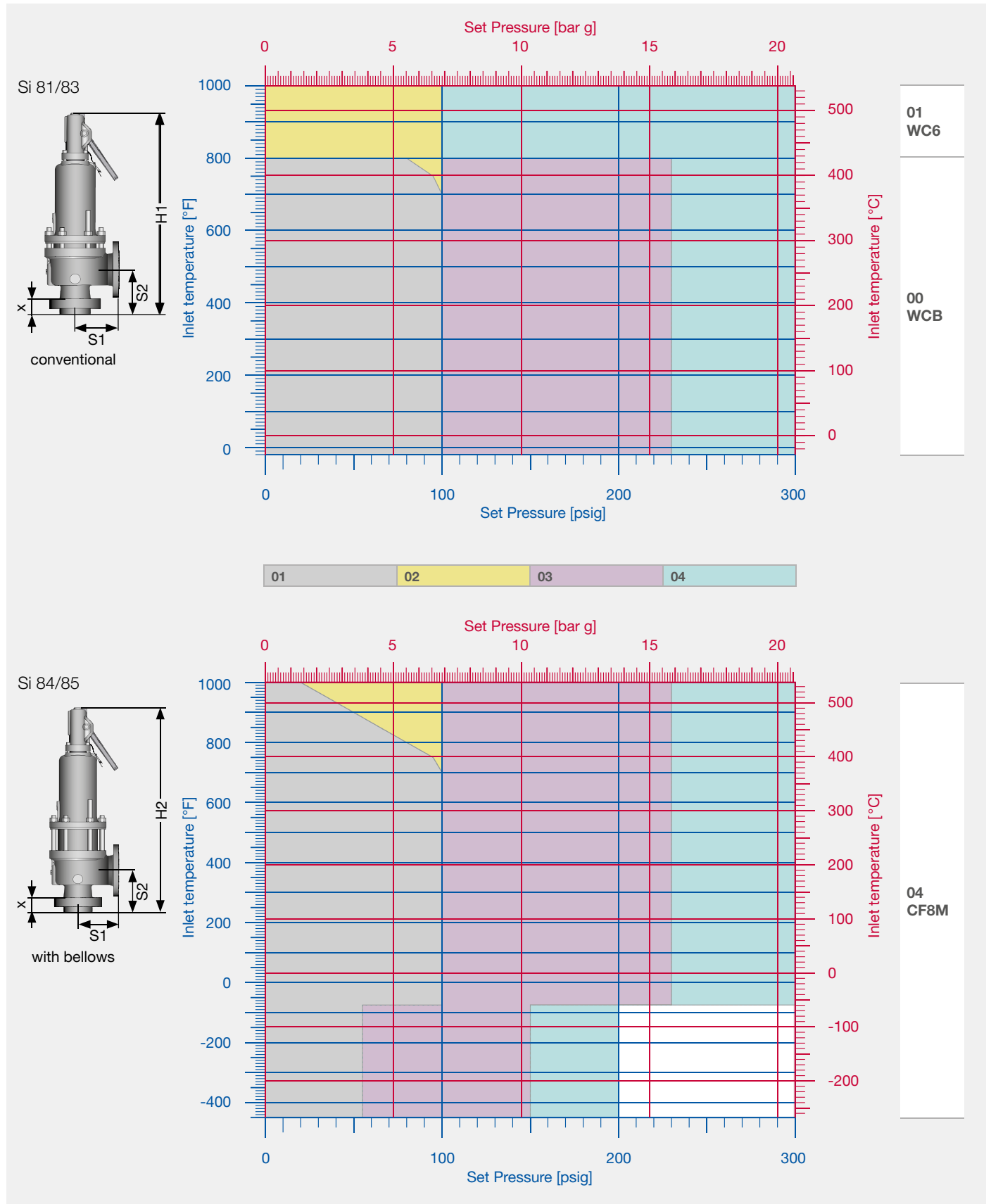

Orifice T

Minimum set pressures

Si 830x.57	3	psig	0.15	bar g
Si 830x	8	psig	0.5	bar g
Si 840x	29	psig	2	bar g

Effective area 26.00 in² / 16774 mm²

Inlet class	01	02	03	04	
Class	150 x 150	300 x 150	300 x 150	300 x 150	
NPS Inlet x outlet	8" x 10"	8" x 10"	8" x 10"	8" x 10"	
S1 [in]	11.00	11.00	11.00	11.00	
S2 [in]	10.87	10.87	10.87	10.87	
X [in]	2.68	2.68	2.68	2.68	
H1 Si 81/83 [in]	50.98	50.98	50.98	53.94	
H2 Si 84/85 [in]	57.87	57.87	57.87	60.83	
Weight Si 81/83 [lbs]	704	730	730	858	
Weight Si 84/85 [lbs]	836	836	836	971	
Inlet temperature	Max. set pressure [psig]				Material code
-51 °F to -21 °F	65	65	120	300	22 LCB
-20 °F to 100 °F	65	65	120	300	
101 °F to 450 °F	65	65	120	300	00 WCB
451 °F to 800 °F	65	65	120	300	
451 °F to 800 °F			120	300	01 WC6
801 °F to 1000 °F			100	215	
-450 °F to -76 °F	50	50	65		
-75 °F to -21 °F	65	65	120		
-20 °F to -100 °F	65	65	120		04 CF8M
101 °F to 450 °F	65	65	120		
451 °F to 800 °F	65	65	120		
801 °F to 1000 °F	20	65	120		
Outlet temperature	Max. outlet pressure [psig]				
Si 81/83@100 °F	30	30	60	100	22
Si 81/83@100 °F	30	30	60	100	00/01
Si 81/83@100 °F	30	30	60		04
Si 84/85@100 °F	30	30	60	100	all

Inlet class	01	02	03	04	
Class	150 x 150	300 x 150	300 x 150	300 x 150	
NPS Inlet x outlet	8" x 10"	8" x 10"	8" x 10"	8" x 10"	
S1 [mm]	279.4	279.4	279.4	279.4	
S2 [mm]	276.2	276.2	276.2	276.2	
X [mm]	68	68	68	68	
H1 Si 81/83 [mm]	1295	1295	1295	1370	
H2 Si 84/85 [mm]	1470	1470	1470	1545	
Weight Si 81/83 [kg]	319	331	331	389	
Weight Si 84/85 [kg]	379	379	379	440	
Inlet temperature	Max. set pressure [bar g]				Material code
-46 °C to -30 °C	4.5	4.5	8.3	20.7	22 LCB
-29 °C to 38 °C	4.5	4.5	8.3	20.7	
39 °C to 232 °C	4.5	4.5	8.3	20.7	00 WCB
233 °C to 427 °C	4.5	4.5	8.3	20.7	
233 °C to 427 °C			8.3	20.7	01 WC6
428 °C to 538 °C			6.9	14.8	
-268 °C to -60 °C	3.4	3.4	4.5		
-59 °C to -30 °C	4.5	4.5	8.3		
-29 °C to 38 °C	4.5	4.5	8.3		04 CF8M
39 °C to 232 °C	4.5	4.5	8.3		
233 °C to 427 °C	4.5	4.5	8.3		
428 °C to 538 °C	1.4	1.4	8.3		
Outlet temperature	Max. outlet pressure [bar g]				
Si 81/83@38 °C	2.1	2.1	4.1	6.9	22
Si 81/83@38 °C	2.1	2.1	4.1	6.9	00/01
Si 81/83@38 °C	2.1	2.1	4.1		04
Si 84/85@38 °C	2.1	2.1	4.1	6.9	all

Orifice T

Selection chart

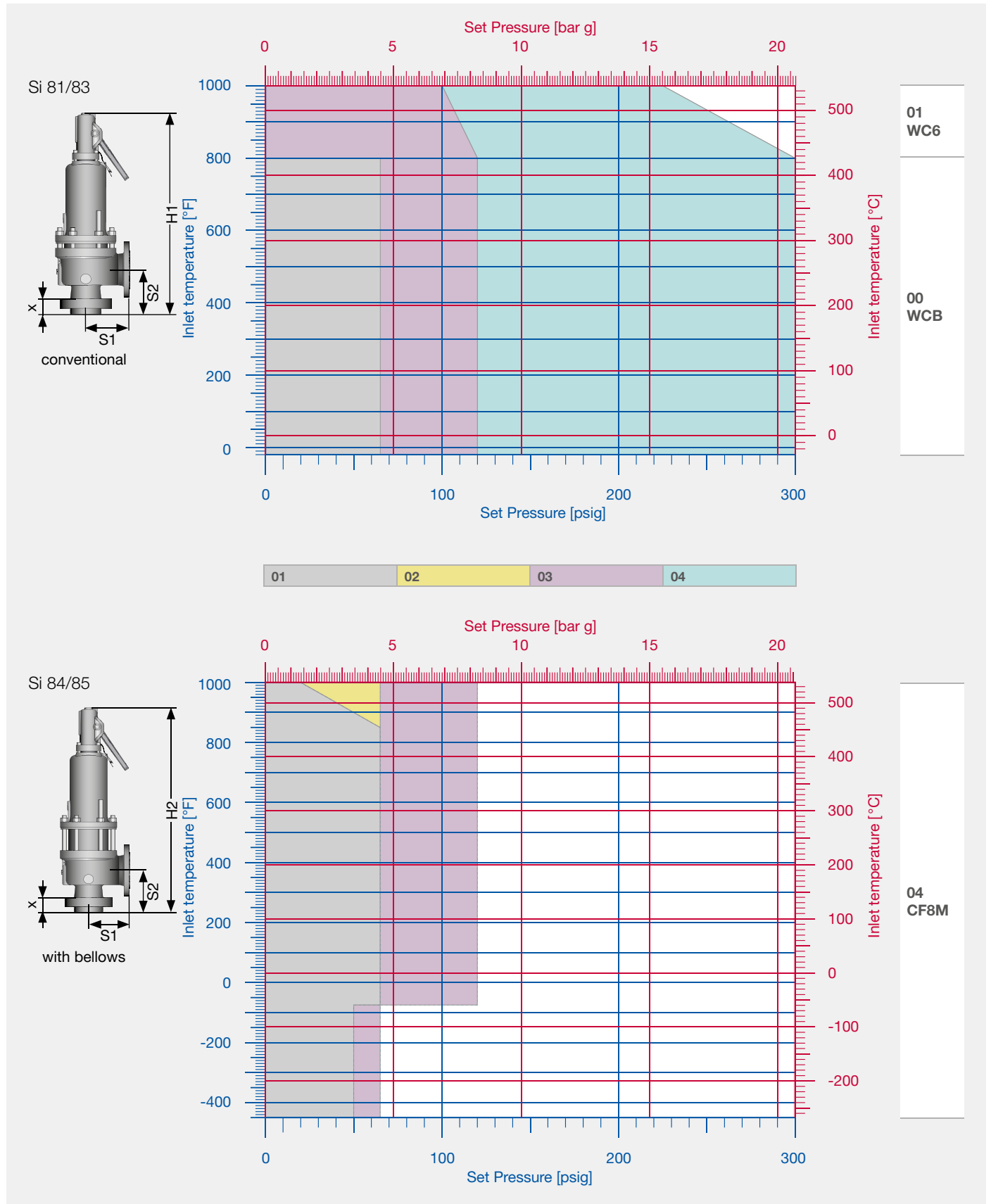

Material code orifice V and W

Material code

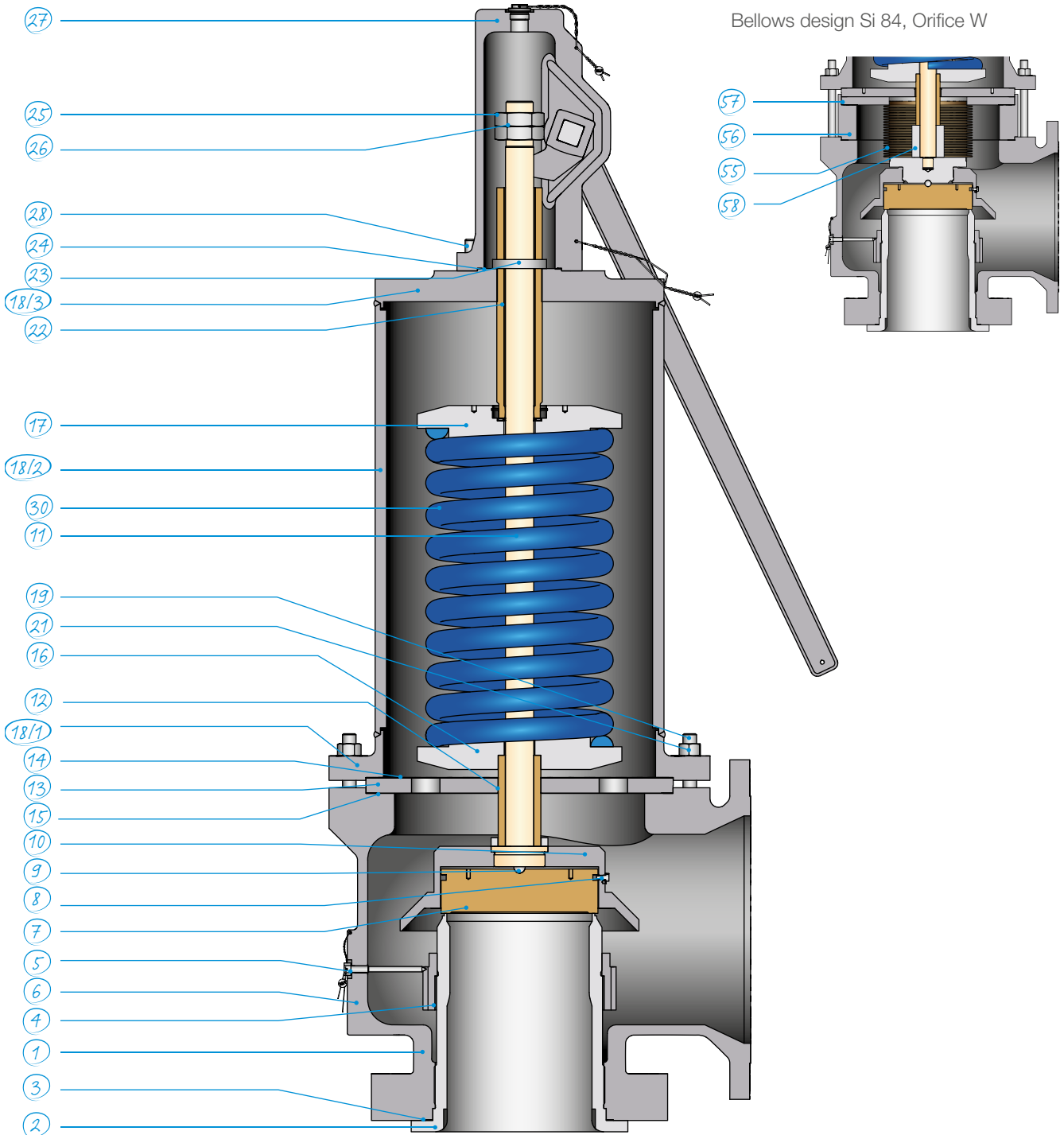

Material code orifice V and W

Material code

Temperature application range			Standard 20 °F to 800 °F -29 °C to 427 °C	High temp. -20 °F to 1000 °F -29 °C to 538 °C	Low temp. -51 °F to 800 °F (-46 °C to 427 °C)	Low temp. -450 °F to 1000 °F -268 °C to 538 °C
Part	Name	Spare part	Material	Material	Material	Material
1	Body		1.0619 SA-216 WCB	1.7357 SA-217M WC6	1.6220 SA 352 LCB	1.4408 SA-351 CF8M
2	Nozzle	*3	1.4408 SA-351 CF8M	1.4408 SA-351 CF8M	1.4408 SA-351 CF8M	1.4408 SA-351 CF8M
3	Flat gasket	*1, 2, 3	1.4401 / Graphite	1.4401 / Graphite	1.4401 / Graphite	1.4401 / Graphite
4	Nozzle ring		1.4408 SA-351 CF8M	1.4408 SA-351 CF8M	1.4408 SA-351 CF8M	1.4408 SA-351 CF8M
5	Set screw		A4-70	A4-70	A4-70	A4-70
6	Flat gasket	*1, 2, 3	1.4401 / Graphite	1.4401 / Graphite	1.4401 / Graphite	1.4401 / Graphite
7	Disc	*2, 3	1.4404 SA-479M Type 316 L	1.4404 SA-479M Type 316 L	1.4404 SA-479M Type 316 L	1.4404 SA-479M Type 316 L
8	Disc retainer		1.4404 SA-479M Type 316 L	1.4404 SA-479M Type 316 L	1.4404 SA-479M Type 316 L	1.4404 SA-479M Type 316 L
9	Ball		1.3541 Stainless steel	1.3541 Stainless steel	1.3541 Stainless steel	Ceramic
10	Disc holder		1.4404 SA-479M Type 316 L	1.4404 SA-479M Type 316 L	1.4404 SA-479M Type 316 L	1.4404 SA-479M Type 316 L
11	Spindle		1.4021 420	1.4021 420	1.4021 420	1.4404 SA-479M Type 316 L
12	Guide bushing		1.4122 MT 440 ¹⁾	1.4122 MT 440 ¹⁾	1.4122 MT 440 ¹⁾	1.4404 SA-479M Type 316 L
13	Guide		1.4122 MT 440 ¹⁾	1.4122 MT 440 ¹⁾	1.4122 MT 440 ¹⁾	1.4404 SA-479M Type 316 L
14	Flat gasket	*1, 2, 3	1.4401 / Graphite	1.4401 / Graphite	1.4401 / Graphite	1.4401 / Graphite
15	Flat gasket	*1, 2, 3	1.4401 / Graphite	1.4401 / Graphite	1.4401 / Graphite	1.4401 / Graphite
16	Spring washer, bottom		1.4404 SA-479M Type 316 L	1.4404 SA-479M Type 316 L	1.4404 SA-479M Type 316 L	1.4404 SA-479M Type 316 L
17	Spring washer, top		1.4404 SA-479M Type 316 L	1.4404 SA-479M Type 316 L	1.4404 SA-479M Type 316 L	1.4404 SA-479M Type 316 L
18/1	Bonnet flange		SA-105M	SA-182M Gr.F11	SA-350M Gr.LF2	SA-182M Gr. F316
18/2	Bonnet pipe		Carbon steel	SA335 Gr. P11	SA-350M Gr.LF2	SA-312M Gr. TP316
18/3	Bonnet cover		SA-105M	SA-182M Gr.F11	SA-350M Gr.LF2	SA-182M Gr. F316
19	Stud, short		SA 193M Gr. B7	SA 193M Gr. B7	SA 193M Gr. B8M	SA-193M Gr. B8M
21	Hex Nut, bonnet		SA-194M Gr. 2H	SA-194M GRADE 2H	SA-194M GRADE 8M	SA-194M GRADE 8M
22	Adjusting screw		1.4122 MT 440 ¹⁾	1.4122 MT 440 ¹⁾	1.4122 MT 440 ¹⁾	1.4404 SA-479M Type 316 L
23	Adj. screw nut		1.4122 MT 440 ¹⁾	1.4122 MT 440 ¹⁾	1.4122 MT 440 ¹⁾	1.4404 SA-479M Type 316 L
24	Flat gasket	*1, 2, 3	1.4401 / Graphite	1.4401 / Graphite	1.4401 / Graphite	1.4401 / Graphite
25	Spindle nut		Carbon steel	Carbon steel	Carbon steel	1.4404 SA-479M Type 316 L
26	Nut		SA-194M GRADE 2H	SA-194M GRADE 2H	SA-194M GRADE 2H	SA-194M GRADE 8M
27	Cap		1.0619 SA-216 WCB	1.0619 SA-216 WCB	1.6220 SA 352 LCB	1.4408 SA-351 CF8M
28	Cylinder screw		SA 193M Gr. B7	SA 193M Gr. B7	SA 193M Gr. B8M	SA-193M Gr. B8M
30	Spring	*3	Alloy steel	Alloy steel	Alloy steel	1.4310 ²⁾ ASTM 302 ²⁾
55	Bellows	*3	1.4404 SA-479M Type 316 L	1.4404 SA-479M Type 316 L	1.4404 SA-479M Type 316 L	1.4404 SA-479M Type 316 L
56	Intermediate bush		1.0619 SA-216 WCB	1.7357 SA-217M WC6	1.6220 SA 352 LCB	1.4408 SA-351 CF8M
57	Top plate		1.4404 SA-479M Type 316 L	1.4404 SA-479M Type 316 L	1.4404 SA-479M Type 316 L	1.4404 SA-479M Type 316 L
58	Lift stop bushing		1.4404 SA-479M Type 316 L	1.4404 SA-479M Type 316 L	1.4404 SA-479M Type 316 L	1.4404 SA-479M Type 316 L

¹⁾ X 39 CrMo 17-1

²⁾ In case of large valve size and high pressure spring material may be chrome steel nickel plated

Spare Parts:

*1 Expendable parts, should be replaced as part of any revision if a damage is visible.

*2 Rework spare parts, should be replaced if a rework is no longer possible.

*3 Long life spare parts, replacement may be required after several years of operation.

IMI Bopp & Reuther reserve the right to technical changes or application of higher quality materials without prior notice. The material design can be tailored to customer specifications at any time upon request.

Orifice V

Minimum set pressures

Si 830x.57	3	psig	0.18	bar g
Si 830x	8	psig	0.5	bar g
Si 840x	15	psig	1	bar g

Effective area 44.91 in² / 28954 mm²

Inlet class	01	03	
Class	150 x 150	300 x 150	
NPS Inlet x outlet	10" x 14"	10" x 14"	
S1 [in]	16.00	16.00	
S2 [in]	12.00	12.00	
X [in]	2.68	2.68	
H1 Si 81/83 [in]	78.94	78.94	
H2 Si 84/85 [in]	80.31	80.31	
Weight Si 81/83 [lbs]	2426	2426.00	
Weight Si 84/85 [lbs]	2304	2304.00	
Inlet temperature	Max. set pressure [psig]		Material code
-51 °F to -21 °F	286	300	22 LCB
-20 °F to 100 °F	286	300	
101 °F to 450 °F	184	300	00 WCB
451 °F to 800 °F	80	300	
451 °F to 800 °F		300	01 WC6
801 °F to 1000 °F		215	
-450 °F to -76 °F	276	300	
-75 °F to -21 °F	276	300	
-20 °F to -100 °F	276	300	04 CF8M
101 °F to 450 °F	184	300	
451 °F to 800 °F	80	300	
801 °F to 1000 °F	20	300	
Outlet temperature	Max. outlet pressure [psig]		
Si 81/83@100 °F	77	77	22
Si 81/83@100 °F	77	77	00/01
Si 81/83@100 °F	77	77	04
Si 84/85@100 °F	77	77	all

Inlet class	01	03	
Class	150 x 150	300 x 150	
NPS Inlet x outlet	10" x 14"	10" x 14"	
S1 [mm]	406.4	406.4	
S2 [mm]	304.8	304.8	
X [mm]	68	68	
H1 Si 81/83 [mm]	2005	2005	
H2 Si 84/85 [mm]	2040	2040	
Weight Si 81/83 [kg]	1100	1100	
Weight Si 84/85 [kg]	1045	1045	
Inlet temperature	Max. set pressure [bar g]		Material code
-46 °C to -30 °C	19.7	20.7	22 LCB
-29 °C to 38 °C	19.7	20.7	
39 °C to 232 °C	12.7	20.7	00 WCB
233 °C to 427 °C	5.5	20.7	
233 °C to 427 °C		20.7	01 WC6
428 °C to 538 °C		14.8	
-268 °C to -60 °C	19.0	20.7	
-59 °C to -30 °C	19.0	20.7	
-29 °C to 38 °C	19.0	20.7	04 CF8M
39 °C to 232 °C	12.7	20.7	
233 °C to 427 °C	5.5	20.7	
428 °C to 538 °C	1.4	20.7	
Outlet temperature	Max. outlet pressure [bar g]		
Si 81/83@38 °C	5.3	5.3	22
Si 81/83@38 °C	5.3	5.3	00/01
Si 81/83@38 °C	5.3	5.3	04
Si 84/85@38 °C	5.3	5.3	all

Orifice V

Selection chart

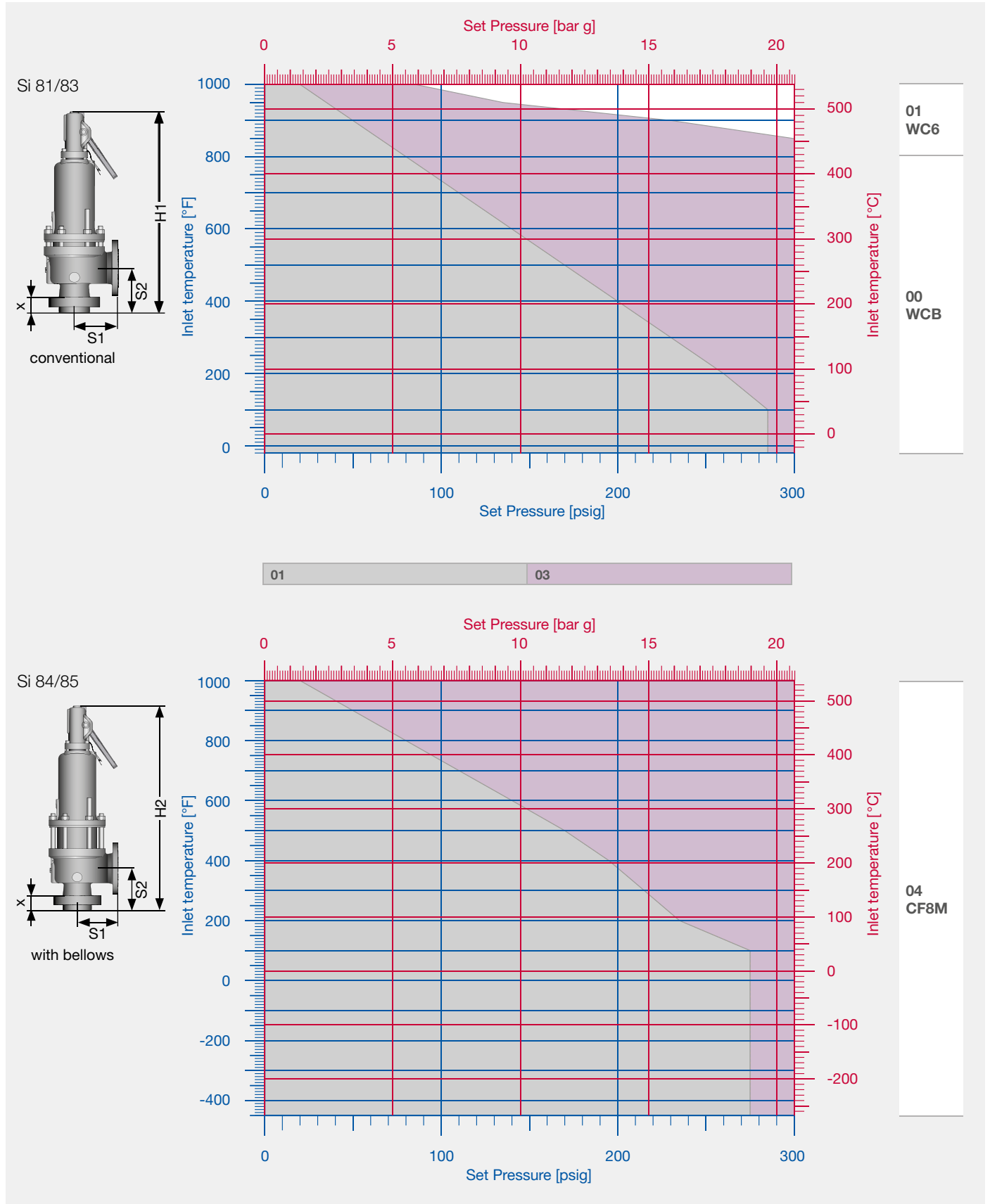

Orifice W

Minimum set pressures

Si 830x.57	3	psig	0.19	bar g
Si 830x	8	psig	0.5	bar g
Si 840x	15	psig	1	bar g

Effective area 64.45 in² / 41583 mm²

Inlet class	01	03	
Class	150 x 150	300 x 150	
NPS Inlet x outlet	12" x 16"	12" x 16"	
S1 [in]	15.98	15.98	
S2 [in]	14.02	14.02	
X [in]	4.02	4.02	
H1 Si 81/83 [in]	78.15	78.15	
H2 Si 84/85 [in]	83.66	83.66	
Weight Si 81/83 [lbs]	2459	2459.00	
Weight Si 84/85 [lbs]	2657	2657.00	
Inlet temperature	Max. set pressure [psig]		Material code
-51 °F to -21 °F	286	300	22 LCB
-20 °F to 100 °F	286	300	
101 °F to 450 °F	184	300	00 WCB
451 °F to 800 °F	80	300	
451 °F to 800 °F		300	01 WC6
801 °F to 1000 °F		215	
-450 °F to -76 °F	276	300	
-75 °F to -21 °F	276	300	
-20 °F to -100 °F	276	300	04 CF8M
101 °F to 450 °F	184	300	
451 °F to 800 °F	80	300	
801 °F to 1000 °F	20	300	
Outlet temperature	Max. outlet pressure [psig]		
Si 81/83@100 °F	77	77	22
Si 81/83@100 °F	77	77	00/01
Si 81/83@100 °F	77	77	04
Si 84/85@100 °F	77	77	all

Inlet class	01	03	
Class	150 x 150	300 x 150	
NPS Inlet x outlet	12" x 16"	12" x 16"	
S1 [mm]	406.0	406.0	
S2 [mm]	356.0	356.0	
X [mm]	102	102	
H1 Si 81/83 [mm]	1985	1985	
H2 Si 84/85 [mm]	2125	2125	
Weight Si 81/83 [kg]	1115	1115	
Weight Si 84/85 [kg]	1205	1205	
Inlet temperature	Max. set pressure [bar g]		Material code
-46 °C to -30 °C	19.7	20.7	22 LCB
-29 °C to 38 °C	19.7	20.7	
39 °C to 232 °C	12.7	20.7	00 WCB
233 °C to 427 °C	5.5	20.7	
233 °C to 427 °C		20.7	01 WC6
428 °C to 538 °C		14.8	
-268 °C to -60 °C	19.0	20.7	
-59 °C to -30 °C	19.0	20.7	
-29 °C to 38 °C	19.0	20.7	04 CF8M
39 °C to 232 °C	12.7	20.7	
233 °C to 427 °C	5.5	20.7	
428 °C to 538 °C	1.4	20.7	
Outlet temperature	Max. outlet pressure [bar g]		
Si 81/83@38 °C	5.3	5.3	22
Si 81/83@38 °C	5.3	5.3	00/01
Si 81/83@38 °C	5.3	5.3	04
Si 84/85@38 °C	5.3	5.3	all

Orifice W

Selection chart

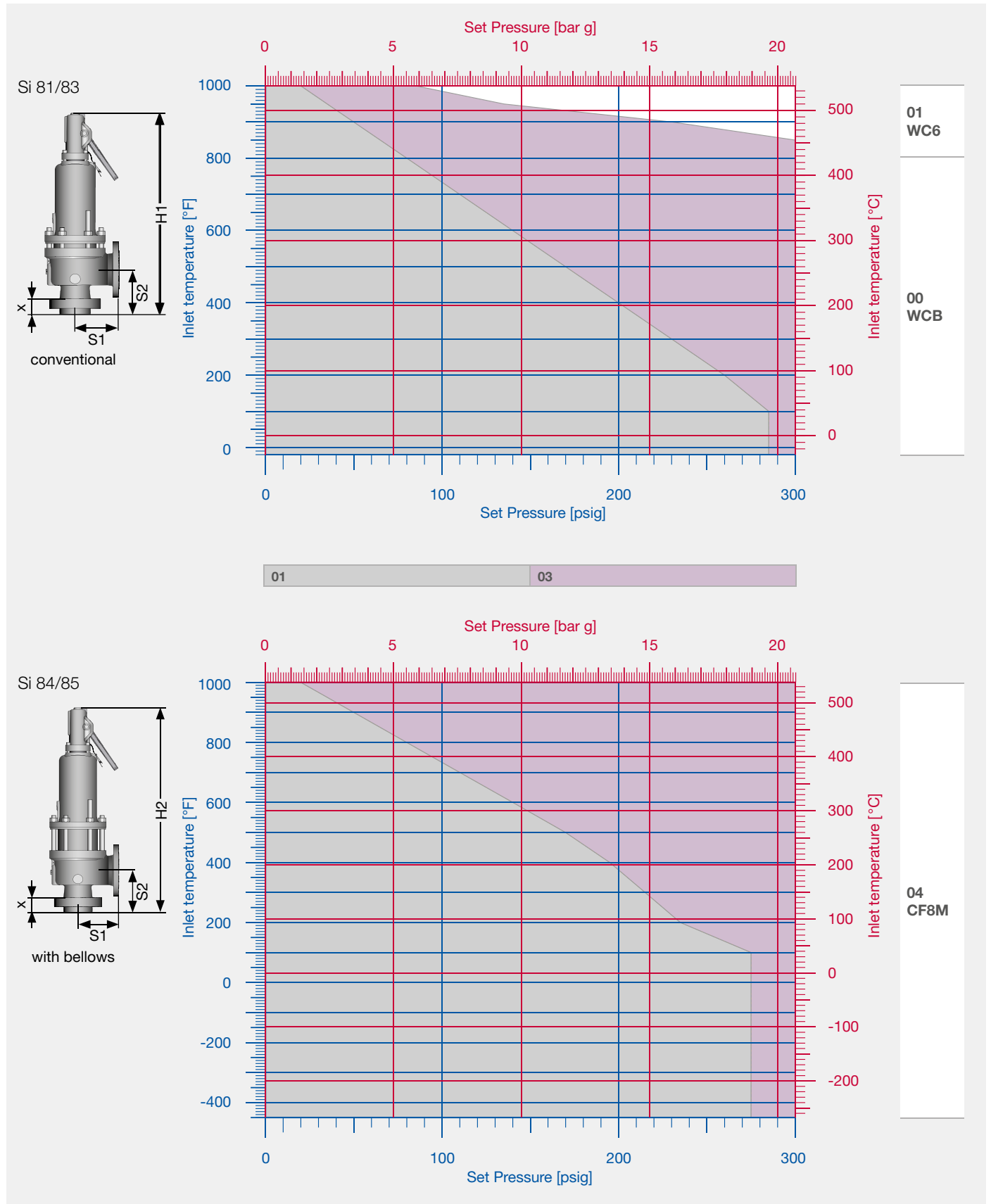

Certified capacities

Air capacities USCS units

Capacity in standard cubic feet per minute of air at 60°F and 10% overpressure. Capacities below 30 psig set pressure are calculated at 3 psig overpressure. Valve discharging to atmospheric pressure.

Capacities certified by National Board of Boiler and Pressure Vessel Inspectors and in accordance with the ASME Boiler and Pressure Vessel Code, Section VIII.

For gases with other specific gravity than air or other temperatures than 60°F, use either ASME Sec. VIII or API Standard 520 calculation basis.

Set Pressure [psig]	Orifice Letter															
	D	E	F	G	H	J	K	L	M	N	P	Q	R	T	V	W
15	71	116	181	297	463	758	1083	1679	2120	2556	3759	6512	9423	15310	26176	37570
20	82	133	209	343	534	874	1249	1936	2444	2947	4334	7508	10864	17651	30178	43315
30	104	169	264	434	675	1106	1580	2450	3093	3728	5484	9499	13746	22333	38183	54804
40	128	208	325	534	831	1361	1944	3015	3806	4588	6748	11690	16916	27484	46988	67443
50	152	247	386	634	987	1616	2309	3580	4519	5448	8013	13880	20086	32634	55793	80081
60	176	286	446	734	1143	1871	2673	4145	5232	6307	9278	16071	23256	37784	64599	92719
70	200	325	507	834	1299	2126	3038	4710	5945	7167	10542	18261	26425	42934	73404	105357
80	224	364	568	934	1454	2381	3402	5275	6659	8027	11807	20452	29595	48085	82209	117996
90	248	403	629	1034	1610	2636	3766	5840	7372	8886	13072	22642	32765	53235	91014	130634
100	272	441	690	1134	1766	2891	4131	6405	8085	9746	14336	24833	35935	58385	99820	143272
120	320	519	812	1334	2077	3401	4859	7534	9511	11466	16865	29214	42275	68686	117430	168549
140	368	597	933	1535	2389	3911	5588	8664	10938	13185	19395	33595	48615	78986	135041	193825
160	416	675	1055	1735	2701	4421	6317	9794	12364	14904	21924	37976	54955	89287	152651	219102
180	464	753	1177	1935	3012	4930	7046	10924	13790	16624	24453	42358	61294	99587	170262	244379
200	512	831	1298	2135	3324	5440	7774	12054	15217	18343	26982	46739	67634	109888	187872	269655
220	560	909	1420	2335	3635	5950	8503	13184	16643	20063	29512	51120	73974	120188	205483	294932
240	608	987	1542	2535	3947	6460	9232	14314	18070	21782	32041	55501	80314	130489	223094	320208
260	656	1065	1663	2735	4258	6970	9961	15444	19496	23502	34570	59882	86653	140790	240704	345485
280	704	1142	1785	2935	4570	7480	10689	16574	20922	25221	37099	64263	92993	151090	258315	370761
300	752	1220	1907	3136	4881	7990	11418	17704	22349	26941	39629	68644	99333	161391	275925	396038
320	800	1298	2028	3336	5193	8500	12147	18834	23775	28660	42158	73026				
340	848	1376	2150	3536	5504	9010	12876	19964	25201	30379	44687	77407				
360	896	1454	2272	3736	5816	9520	13604	21093	26628	32099	47216	81788				
380	944	1532	2394	3936	6128	10030	14333	22223	28054	33818	49745	86169				
400	992	1610	2515	4136	6439	10540	15062	23353	29480	35538	52275	90550				
450	1112	1804	2820	4637	7218	11815	16884	26178	33046	39836	58598	101503				
500	1232	1999	3124	5137	7997	13090	18705	29003	36612	44135	64921	112456				
550	1352	2194	3428	5637	8776	14365	20527	31828	40178	48434	71244	123409				
600	1472	2389	3732	6137	9555	15640	22349	34652	43744	52732	77567	134361				
650	1592	2583	4037	6638	10333	16915	24171	37477	47310	57031	83890					
700	1712	2778	4341	7138	11112	18190	25993	40302	50876	61329	90213					
800	1952	3168	4949	8139	12670	20740	29637	45952	58008	69927	102859					
900	2192	3557	5558	9139	14228	23289	33280	51601	65140	78524	115506					
1000	2432	3946	6166	10140	15786	25839	36924	57251	72272	87121	128152					
1100	2672	4336	6775	11141	17343	28389	40568	62900	79403							
1200	2912	4725	7383	12141	18901	30939	44211	68550								
1300	3152	5115	7992	13142	20459	33489	47855	74199								
1400	3392	5504	8600	14142	22016	36039	51499	79849								
1500	3632	5894	9209	15143	23574	38589	55142	85499								
1600	3872	6283	9817	16144	25132	41138	58786									
1700	4112	6672	10426	17144	26690	43688	62430									
1800	4352	7062	11034	18145	28247	46238	66074									
1900	4592	7451	11643	19145	29805	48788	69717									
2000	4832	7841	12251	20146	31363	51338	73361									
2500	6032	9788	15294	25149	39152	64087										
3000	7232	11735	18336	30152												
3500	8432	13682	21378	35155												
4000	9632	15629	24421	40159												
4500	10832	17577	27463	45162												
5000	12032	19524	30506	50165												
5500	13232	21471														
6000	14432	23418														

Certified capacities

Air capacities SI units

Capacity in standard cubic meters per minute of air at 16 °C and 10% over-pressure. Capacities below 2.1 bar-g set pressure are calculated at 0.21 bar-g over-pressure. Valve discharging to atmospheric pressure.

Capacities certified by National Board of Boiler and Pressure Vessel Inspectors and in accordance with the ASME Boiler and Pressure Vessel Code, Section VIII.

For gases with other specific gravity than air or other temperatures than 16 °C, use either ASME Sec. VIII or API Standard 520 calculation basis.

Set Pressure [bar g]	Orifice Letter															
	D	E	F	G	H	J	K	L	M	N	P	Q	R	T	V	W
1	2	3	5	8	13	21	30	47	59	71	105	182	263	427	730	1048
2	3	5	7	12	19	31	44	68	86	103	152	263	381	619	1059	1520
3	4	6	10	16	25	41	59	91	115	139	204	353	511	830	1418	2035
4	5	8	12	20	32	52	74	114	144	174	256	443	641	1041	1780	2555
5	6	10	15	24	38	62	89	137	173	209	308	533	771	1253	2141	3074
6	7	11	17	28	44	73	104	161	203	244	360	623	901	1464	2503	3593
7	8	13	20	33	51	83	119	184	232	280	411	713	1031	1676	2865	4112
8	9	14	22	37	57	93	134	207	261	315	463	803	1162	1887	3226	4631
9	10	16	25	41	64	104	149	230	291	350	515	893	1292	2099	3588	5150
10	11	18	27	45	70	114	163	253	320	386	567	983	1422	2310	3950	5669
11	12	19	30	49	76	125	178	277	349	421	619	1073	1552	2522	4311	6188
12	13	21	32	53	83	135	193	300	379	456	671	1163	1682	2733	4673	6707
13	14	22	35	57	89	146	208	323	408	492	723	1253	1812	2945	5034	7226
14	15	24	37	61	96	156	223	346	437	527	775	1342	1943	3156	5396	7745
15	16	26	40	65	102	167	238	369	466	562	827	1432	2073	3368	5758	8264
16	17	27	42	70	108	177	253	393	496	598	879	1522	2203	3579	6119	8783
17	18	29	45	74	115	188	268	416	525	633	931	1612	2333	3791	6481	9302
18	19	30	47	78	121	198	283	439	554	668	983	1702	2463	4002	6843	9821
19	20	32	50	82	127	209	298	462	584	703	1035	1792	2594	4214	7204	10340
20	21	34	52	86	134	219	313	485	613	739	1087	1882	2724	4425	7566	10859
22	23	37	57	94	147	240	343	532	671	809	1191	2062				
24	25	40	62	102	159	261	373	578	730	880	1294	2242				
26	27	43	67	111	172	282	403	625	789	951	1398	2422				
28	29	46	72	119	185	303	433	671	847	1021	1502	2602				
30	31	50	77	127	198	324	463	718	906	1092	1606	2782				
35	35	58	90	148	230	376	538	834	1052	1268	1866	3232				
40	40	66	102	168	262	429	612	950	1199	1445	2125	3682				
45	45	73	115	189	294	481	687	1066	1345	1621	2385					
50	50	81	127	209	326	533	762	1182	1492	1798	2645					
55	55	89	140	230	358	586	837	1298	1638	1975	2904					
60	60	97	152	250	390	638	912	1414	1784	2151	3164					
65	65	105	165	271	422	690	987	1530	1931	2328	3424					
70	70	113	177	292	454	743	1061	1646	2077							
75	75	121	190	312	486	795	1136	1762	2224							
80	80	129	202	333	518	847	1211	1878								
85	85	137	215	353	550	900	1286	1994								
90	90	145	227	374	582	952	1361	2110								
95	95	153	240	394	614	1005	1435	2226								
100	100	161	252	415	646	1057	1510	2342								
120	119	193	302	497	774	1266	1810									
140	139	225	352	579	902	1476	2109									
160	159	257	402	661	1030	1685										
180	178	289	452	744	1158	1895										
200	198	321	502	826												
220	218	353	552	908												
240	238	385	602	990												
260	257	417	652													
280	277	449	702													
300	297	481	752													
350	346	561														
400	395	641														
414	409	664														

Certified capacities

Saturated Steam capacities USCS units

Capacity in pounds per hour of saturated steam at 10% overpressure. Capacities below 30 psig set pressure are calculated at 3 psig overpressure. Valve discharging to atmospheric pressure.

Capacities certified by National Board of Boiler and Pressure Vessel Inspectors and in accordance with the ASME Boiler and Pressure Vessel Code, Section VIII. The maximum permissible set pressure on steam is 2900 psig.

The Napier factor is considered to the capacity of pressures over 1500 psig. For other steam condition, use either ASME Sec. VIII or API Standard 520 calculation basis.

Set Pressure [psig]	Orifice Letter															
	D	E	F	G	H	J	K	L	M	N	P	Q	R	T	V	W
15	201	326	510	838	1304	2135	3051	4731	5972	7199	10590	18343	26544	43127	73733	105830
20	232	376	587	966	1504	2462	3518	5454	6885	8300	12209	21148	30603	49721	85007	122012
30	293	476	743	1222	1903	3115	4451	6901	8711	10501	15447	26758	38720	62910	107556	154376
40	361	585	915	1504	2342	3833	5477	8492	10720	12923	19009	32928	47649	77418	132359	189976
50	428	695	1086	1786	2780	4551	6504	10084	12729	15345	22572	39099	56578	91925	157162	225576
60	496	805	1257	2068	3219	5269	7530	11675	14738	17767	26134	45269	65507	106433	181965	261176
70	564	914	1429	2350	3658	5988	8556	13267	16747	20188	29696	51440	74437	120940	206768	296777
80	631	1024	1600	2632	4097	6706	9583	14858	18756	22610	33258	57610	83366	135448	231572	332377
90	699	1134	1772	2913	4536	7424	10609	16449	20765	25032	36821	63781	92295	149955	256375	367977
100	766	1244	1943	3195	4974	8142	11635	18041	22774	27453	40383	69951	101224	164463	281178	403577
120	902	1463	2286	3759	5852	9579	13688	21224	26792	32297	47507	82292	119082	193478	330784	474778
140	1037	1682	2629	4323	6729	11015	15741	24406	30810	37140	54632	94633	136941	222493	380391	545978
160	1172	1902	2972	4886	7607	12452	17794	27589	34828	41984	61756	106974	154799	251508	429997	617179
180	1307	2121	3314	5450	8485	13888	19846	30772	38846	46827	68881	119315	172657	280523	479603	688379
200	1442	2341	3657	6014	9362	15325	21899	33955	42863	51671	76005	131656	190516	309539	529210	759580
220	1578	2560	4000	6578	10240	16761	23952	37138	46881	56514	83130	143997	208374	338554	578816	830780
240	1713	2779	4343	7141	11117	18198	26005	40320	50899	61357	90254	156338	226232	367569	628422	901981
260	1848	2999	4686	7705	11995	19635	28057	43503	54917	66201	97379	168679	244090	396584	678029	973181
280	1983	3218	5028	8269	12873	21071	30110	46686	58935	71044	104503	181020	261949	425599	727635	1044382
300	2118	3438	5371	8832	13750	22508	32163	49869	62953	75888	111628	193361	279807	454614	777242	1115582
320	2254	3657	5714	9396	14628	23944	34216	53052	66971	80731	118752	205702				
340	2389	3876	6057	9960	15505	25381	36268	56234	70989	85575	125877	218043				
360	2524	4096	6400	10524	16383	26817	38321	59417	75006	90418	133001	230384				
380	2659	4315	6742	11087	17260	28254	40374	62600	79024	95261	140126	242725				
400	2795	4535	7085	11651	18138	29690	42427	65783	83042	100105	147250	255067				
450	3133	5083	7942	13060	20332	33281	47559	73740	93087	112213	165062	285919				
500	3471	5631	8799	14470	22526	36873	52691	81697	103132	124322	182873	316772				
550	3809	6180	9656	15879	24720	40464	57822	89654	113176	136430	200684	347624				
600	4147	6728	10513	17288	26914	44055	62954	97611	123221	148539	218495	378477				
650	4485	7277	11370	18698	29108	47646	68086	105568	133266	160648	236307					
700	4823	7825	12227	20107	31302	51238	73218	113525	143310	172756	254118					
750	5161	8374	13084	21516	33496	54829	78350	121482	153355	184865	271929					
800	5499	8922	13941	22925	35690	58420	83482	129439	163400	196973	289740					
850	5837	9471	14798	24335	37884	62012	88614	137396	173445	209082	307552					
900	6175	10019	15655	25744	40078	65603	93746	145353	183489	221190	325363					
950	6513	10568	16512	27153	42272	69194	98878	153310	193534	233299	343174					
1000	6851	11116	17369	28563	44466	72785	104009	161267	203579	245408	360985					
1100	7527	12213	19083	31381	48853	79968	114273	177181	223668							
1200	8203	13310	20797	34200	53241	87151	124537	193095								
1300	8879	14407	22511	37018	57629	94333	134801	209009								
1400	9555	15504	24225	39837	62017	101516	145065	224923								
1500	10280	16681	26064	42860	66724	109219	156073	241992								
1600	11032	17901	27971	45996	71605	117210	167491									
1700	11799	19146	29916	49195	76585	125362	179141									
1800	12584	20419	31905	52465	81677	133696	191050									
1900	13388	21723	33943	55817	86894	142236	203254									
2000	14214	23064	36037	59260	92254	151010	215791									
2200	15944	25872	40425	66477	103489	169400	242071									
2400	17811	28900	45157	74257	115601	189226										
2600	19863	32230	50360	82813	128920	211029										
2800	22181	35992	56237	92478												
2900	23478	38097	59526	97887												

Certified capacities

Saturated Steam capacities SI units

Capacity in kilograms per hour of saturated steam at 10% overpressure. Capacities below 2.1 bar g set pressure are calculated at 0.21 bar g overpressure. Valve discharging to atmospheric pressure.

Capacities certified by National Board of Boiler and Pressure Vessel Inspectors and in accordance with the ASME Boiler and Pressure Vessel Code, Section VIII. The maximum permissible set pressure on steam is 200 bar g.

The Napier factor is considered to the capacity of pressures over 103 bar g. For other steam condition, use either ASME Sec. VIII or API Standard 520 calculation basis.

Set Pressure [bar g]	Orifice Letter															
	D	E	F	G	H	J	K	L	M	N	P	Q	R	T	V	W
1	90	146	228	374	583	954	1363	2113	2668	3216	4730	8194	11857	19265	32937	47275
2	130	211	330	543	845	1383	1977	3065	3869	4664	6861	11885	17198	27942	47771	68567
3	174	283	442	727	1132	1853	2648	4106	5183	6248	9190	15919	23035	37427	63987	91842
4	219	355	555	913	1421	2325	3323	5152	6504	7841	11533	19978	28910	46971	80305	115262
5	263	427	668	1098	1709	2798	3998	6199	7826	9434	13877	24038	34784	56515	96622	138683
6	308	500	780	1283	1998	3271	4674	7246	9148	11027	16221	28097	40658	66059	112940	162104
7	352	572	893	1469	2287	3743	5349	8293	10469	12620	18564	32157	46533	75604	129257	185524
8	397	644	1006	1654	2575	4216	6024	9340	11791	14214	20908	36216	52407	85148	145575	208945
9	441	716	1119	1840	2864	4688	6699	10387	13113	15807	23251	40275	58281	94692	161893	232366
10	486	788	1232	2025	3153	5161	7374	11434	14434	17400	25595	44335	64156	104236	178210	255787
11	530	860	1344	2211	3441	5633	8050	12481	15756	18993	27938	48394	70030	113781	194528	279207
12	575	933	1457	2396	3730	6106	8725	13528	17077	20586	30282	52454	75904	123325	210845	302628
13	619	1005	1570	2581	4019	6578	9400	14575	18399	22180	32625	56513	81779	132869	227163	326049
14	664	1077	1683	2767	4307	7051	10075	15622	19721	23773	34969	60573	87653	142413	243480	349469
15	708	1149	1795	2952	4596	7523	10751	16669	21042	25366	37312	64632	93527	151957	259798	372890
16	753	1221	1908	3138	4885	7996	11426	17716	22364	26959	39656	68692	99401	161502	276115	396311
17	797	1293	2021	3323	5173	8468	12101	18763	23686	28552	41999	72751	105276	171046	292433	419731
18	842	1366	2134	3509	5462	8941	12776	19810	25007	30145	44343	76811	111150	180590	308750	443152
19	886	1438	2246	3694	5751	9413	13452	20857	26329	31739	46686	80870	117024	190134	325068	466573
20	930	1510	2359	3879	6039	9886	14127	21904	27651	33332	49030	84929	122899	199679	341385	489993
22	1019	1654	2585	4250	6617	10831	15477	23998	30294	36518	53717	93048				
24	1108	1799	2810	4621	7194	11776	16828	26092	32937	39705	58404	101167				
26	1197	1943	3036	4992	7771	12721	18178	28185	35580	42891	63091	109286				
28	1286	2087	3261	5363	8349	13666	19529	30279	38224	46077	67778	117405				
30	1375	2232	3487	5734	8926	14611	20879	32373	40867	49264	72465	125524				
35	1598	2592	4051	6661	10370	16974	24255	37608	47475	57230	84183	145821				
40	1820	2953	4614	7588	11813	19336	27632	42843	54083	65196	95901	166119				
45	2042	3314	5178	8515	13256	21699	31008	48078	60692	73162	107618					
50	2265	3675	5742	9442	14700	24062	34384	53312	67300	81128	119336					
55	2487	4036	6306	10370	16143	26424	37760	58547	73908	89094	131054					
60	2710	4397	6870	11297	17586	28787	41136	63782	80516	97060	142771					
65	2932	4757	7433	12224	19030	31150	44512	69017	87124	105026	154489					
70	3154	5118	7997	13151	20473	33512	47889	74251	93733							
75	3377	5479	8561	14078	21916	35875	51265	79486	100341							
80	3599	5840	9125	15005	23360	38237	54641	84721								
85	3821	6201	9689	15932	24803	40600	58017	89956								
90	4044	6562	10253	16860	26247	42963	61393	95190								
95	4266	6922	10816	17787	27690	45325	64769	100425								
100	4496	7296	11399	18745	29182	47768	68260	105838								
105	4741	7692	12019	19765	30769	50366	71972									
110	4988	8094	12647	20798	32378	52999	75734									
115	5240	8502	13285	21846	34009	55670	79551									
120	5495	8917	13932	22911	35667	58383	83428									
125	5755	9338	14591	23993	37352	61141	87369									
130	6019	9767	15261	25095	39067	63949	91382									
140	6564	10650	16641	27365	42602	69734	99649									
150	7133	11575	18085	29740	46298	75786	108296									
160	7734	12549	19608	32243	50195	82164										
170	8373	13586	21228	34907	54343	88953										
180	9061	14702	22972	37776	58809	96264										
190	9813	15922	24879	40912												
200	10650	17281	27002	44403												

Certified capacities

Water capacities USCS units

Capacity in gallons per minute of water at 10% overpressure. Capacities below 30 psig set pressure are calculated at 3 psig overpressure. Valve discharging to atmospheric pressure.

Capacities certified by National Board of Boiler and Pressure Vessel Inspectors and in accordance with the ASME Boiler and Pressure Vessel Code, Section VIII.

For liquids with other specific gravity than water, use either ASME Sec. VIII or API Standard 520 calculation basis.

Set Pressure [psig]	Orifice Letter															
	D	E	F	G	H	J	K	L	M	N	P	Q	R	T	V	W
15	15	25	38	63	98	160	229	355	449	541	796	1378	1994	3240	5540	7951
20	17	28	43	71	111	181	259	402	507	611	899	1558	2254	3663	6262	8988
30	20	33	52	85	133	217	310	481	608	732	1077	1866	2700	4387	7501	10766
40	23	38	60	98	153	251	358	556	702	846	1244	2155	3118	5066	8661	12432
50	26	43	67	110	171	280	401	621	784	945	1391	2409	3486	5664	9684	13899
60	28	47	73	121	188	307	439	681	859	1036	1524	2639	3819	6205	10608	15226
70	31	51	79	130	203	332	474	735	928	1119	1646	2851	4125	6702	11458	16446
80	33	54	85	139	217	355	507	786	992	1196	1759	3047	4410	7165	12249	17581
90	35	57	90	148	230	376	538	834	1052	1269	1866	3232	4677	7599	12992	18648
100	37	61	95	156	242	397	567	879	1109	1337	1967	3407	4930	8010	13695	19656
120	40	66	104	170	265	434	621	963	1215	1465	2155	3732	5401	8775	15002	21533
140	44	72	112	184	287	469	671	1040	1312	1582	2327	4031	5833	9478	16204	23258
160	47	77	120	197	306	502	717	1111	1403	1691	2488	4310	6236	10132	17323	24864
180	49	81	127	209	325	532	760	1179	1488	1794	2639	4571	6615	10747	18374	26372
200	52	86	134	220	343	561	801	1243	1569	1891	2782	4818	6972	11328	19368	27798
220	55	90	140	231	359	588	841	1303	1645	1983	2917	5053	7313	11881	20313	29155
240	57	94	147	241	375	614	878	1361	1718	2071	3047	5278	7638	12409	21216	30452
260	59	98	153	251	391	639	914	1417	1789	2156	3171	5494	7950	12916	22082	31695
280	62	101	158	260	405	664	948	1470	1856	2237	3291	5701	8250	13404	22916	32892
300	64	105	164	270	420	687	982	1522	1921	2316	3407	5901	8539	13874	23720	34046
320	66	108	169	278	433	709	1014	1572	1984	2392	3518	6095				
340	68	112	175	287	447	731	1045	1620	2045	2466	3627	6282				
360	70	115	180	295	460	752	1075	1667	2105	2537	3732	6464				
380	72	118	184	303	472	773	1105	1713	2162	2607	3834	6641				
400	74	121	189	311	485	793	1133	1757	2218	2674	3934	6814				
450	78	128	201	330	514	841	1202	1864	2353	2836	4172	7227				
500	82	135	212	348	542	887	1267	1965	2480	2990	4398	7618				
550	86	142	222	365	568	930	1329	2061	2601	3136	4613	7990				
600	90	148	232	381	593	971	1388	2152	2717	3275	4818	8345				
650	94	154	241	397	618	1011	1445	2240	2828	3409	5015					
700	97	160	250	412	641	1049	1499	2325	2935	3538	5204					
800	104	171	268	440	685	1122	1603	2485	3137	3782	5563					
900	110	182	284	467	727	1190	1700	2636	3328	4011	5901					
1000	116	192	299	492	766	1254	1792	2779	3508	4228	6220					
1100	122	201	314	516	804	1315	1880	2914	3679							
1200	127	210	328	539	839	1374	1963	3044								
1300	133	218	341	561	874	1430	2043	3168								
1400	138	227	354	582	907	1484	2120	3288								
1500	142	235	367	603	938	1536	2195	3403								
1600	147	242	379	623	969	1586	2267									
1700	152	250	390	642	999	1635	2337									
1800	156	257	402	660	1028	1683	2404									
1900	160	264	413	678	1056	1729	2470									
2000	165	271	423	696	1083	1774	2534									
2500	184	303	473	778	1211	1983										
3000	202	332	518	852												
3500	218	358	560	921												
4000	233	383	599													
4500	247	406	635													
5000	260	428	669													
5500	273	449														
6000	285	469														

Certified capacities

Water capacities SI units

Capacity in liters per minute of water at 10% overpressure. Capacities below 2.1 bar g set pressure are calculated at 0.21 bar g overpressure. Valve discharging to atmospheric pressure.

Capacities certified by National Board of Boiler and Pressure Vessel Inspectors and in accordance with the ASME Boiler and Pressure Vessel Code, Section VIII.

For liquids with other specific gravity than water, use either ASME Sec. VIII or API Standard 520 calculation basis.

Set Pressure [bar g]	Orifice Letter															
	D	E	F	G	H	J	K	L	M	N	P	Q	R	T	V	W
1	56	91	143	235	366	599	856	1327	1675	2019	2970	5145	7445	12096	20680	29682
2	75	124	193	318	495	810	1157	1794	2265	2730	4016	6957	10067	16356	27964	40137
3	92	151	236	389	605	990	1415	2194	2770	3339	4911	8507	12311	20001	34196	49082
4	106	175	273	449	699	1143	1634	2533	3198	3855	5671	9823	14215	23096	39486	56675
5	119	195	305	502	781	1278	1827	2833	3576	4310	6340	10983	15893	25822	44147	63364
6	130	214	334	550	856	1400	2001	3103	3917	4722	6946	12031	17410	28286	48360	69412
7	140	231	361	594	924	1513	2162	3351	4231	5100	7502	12995	18805	30553	52235	74973
8	150	247	386	635	988	1617	2311	3583	4523	5452	8020	13892	20103	32662	55842	80150
9	159	262	409	673	1048	1715	2451	3800	4797	5783	8507	14735	21322	34643	59229	85012
10	168	276	431	709	1104	1808	2584	4006	5057	6096	8967	15532	22476	36517	62433	89610
11	176	290	453	744	1158	1896	2710	4201	5304	6393	9404	16290	23573	38300	65480	93984
12	184	302	473	777	1210	1981	2830	4388	5539	6678	9822	17014	24621	40003	68392	98163
13	191	315	492	809	1259	2061	2946	4567	5766	6950	10224	17709	25626	41636	71184	102172
14	198	327	510	839	1307	2139	3057	4740	5983	7213	10609	18378	26594	43208	73872	106028
15	205	338	528	869	1353	2214	3164	4906	6193	7466	10982	19023	27527	44724	76464	109750
16	212	349	546	897	1397	2287	3268	5067	6396	7711	11342	19647	28430	46191	78972	113349
17	219	360	563	925	1440	2357	3369	5223	6593	7948	11691	20251	29305	47613	81402	116838
18	225	370	579	952	1482	2426	3466	5374	6784	8178	12030	20838	30154	48993	83762	120225
19	231	381	595	978	1522	2492	3561	5522	6970	8402	12360	21409	30981	50336	86058	123519
20	237	390	610	1003	1562	2557	3654	5665	7151	8621	12681	21966	31786	51643	88293	126728
22	249	410	640	1052	1638	2682	3832	5942	7500	9041	13300	23038				
24	260	428	668	1099	1711	2801	4002	6206	7834	9444	13891	24062				
26	270	445	696	1144	1781	2915	4166	6459	8154	9829	14458	25045				
28	281	462	722	1187	1848	3025	4323	6703	8462	10200	15004	25990				
30	290	478	747	1229	1913	3131	4475	6938	8759	10558	15531	26902				
35	314	517	807	1327	2066	3382	4833	7494	9460	11404	16775	29058				
40	335	552	863	1419	2209	3616	5167	8012	10114	12192	17933	31064				
45	356	586	915	1505	2343	3835	5480	8498	10727	12931	19021					
50	375	617	965	1586	2470	4043	5777	8957	11307	13631	20050					
55	393	648	1012	1664	2590	4240	6059	9394	11859	14296	21029					
60	411	676	1057	1738	2705	4429	6328	9812	12386	14932	21964					
65	428	704	1100	1809	2816	4609	6587	10213	12892	15541	22861					
70	444	731	1141	1877	2922	4783	6835	10598	13379							
75	459	756	1182	1943	3025	4951	7075	10970	13849							
80	474	781	1220	2007	3124	5114	7307	11330								
85	489	805	1258	2068	3220	5271	7532	11679								
90	503	828	1294	2128	3313	5424	7751	12017								
95	517	851	1330	2187	3404	5572	7963	12347								
100	530	873	1364	2244	3493	5717	8170	12667								
120	581	957	1495	2458	3826	6263	8950									
140	628	1033	1614	2655	4133	6765	9667									
160	671	1104	1726	2838	4418	7232										
180	712	1171	1830	3010	4686	7670										
200	750	1235	1929	3173												
220	787	1295	2024	3328												
240	822	1353	2114	3476												
260	855	1408	2200													
280	887	1461	2283													
300	919	1512	2363													
350	992	1634														
400	1061	1746														
414	1079	1777														

Heating jacket

Safety valve with heating jacket (Option .18)

Hardening or solidification of highly viscous media in the safety valve can interfere with the function or closing and hence lead to dangerous operating conditions. Media with a tendency to conglutination or crystallization can block the seat and moving parts. This can usually be remedied by maintaining the temperature of the Fluid before and during the discharge. Monitoring and heating the

pipe will often not provide the required heat to the inlet of the safety valve. Equipping the safety valve with a heating jacket will solve this problem. Typical applications for safety valves with heating jacket (option code .18) include ammonium nitrate, acrylic acid, sulphuric acid, fluoropolymers, polypropylene, olefins, and tar.

The safety valve should be equipped with bellows to protect the spindle and guides.

Additional heating of the isolating spacer is integrated in the heating circuit by means of piping. The bellows will not be required if the fluid does not tend to solidify in the outlet of the safety valve.

Purging the seat area with steam can serve as a further measure for protecting the safety valve seat from conglutination. The purge connection (option .32) can also be combined with the heating jacket.

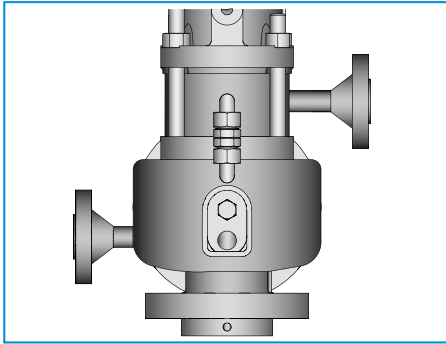

.18 Heating jacket with flange connection for safety valve with bellows

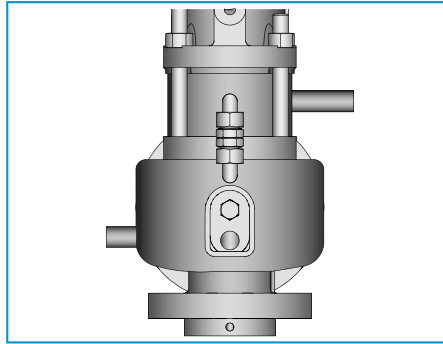

.18 Heating jacket with threaded connection for safety valve with bellows

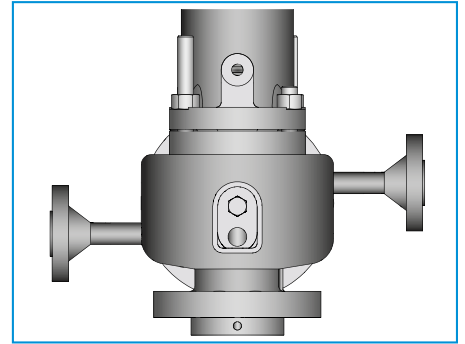

.18 Heating jacket with flange connection for conventional safety valve

Safety valve Inlet size	NPS Inch	1	1½	2	3	4	6	8	10	12	≥ 250	
Heating jacket connection	Flange	NPS ½ Class 150					NPS 1 Class 150					
	Thread	NPT ⅜					NPT ¾					
Max. heating jacket working pressure [bar g] ¹⁾	50 °C				18					16	10	
	150 °C				18					14	9	
	200 °C				18					13	8	
	300 °C				18					12	7	
Heating jacket material		Stainless steel 1.4301 ²⁾										

¹⁾ Nominal pressure rating for the heating jacket at 50 °C. The heating jacket is labelled in compliance with the Pressure Equipment Directive.

²⁾ Depending on the heating jacket design or availability of materials, we reserve the right to use higher quality 1.4404 or 1.4571 stainless steel.

Other connections, pressure ratings or materials available upon request. Safety valves with heating jacket have no support brackets.

Options

Technical design options

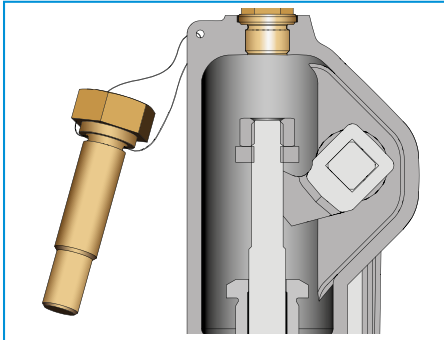

B Test gag: Blocking of the safety valve for pressure testing the pressure system

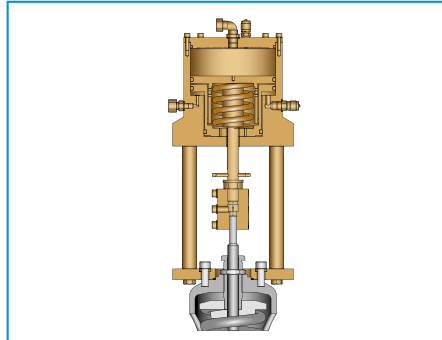

AK Pneumatic actuator improves the tightness, reduces the functional pressure differences, controls the open- and close dynamic and can be used as remote control.

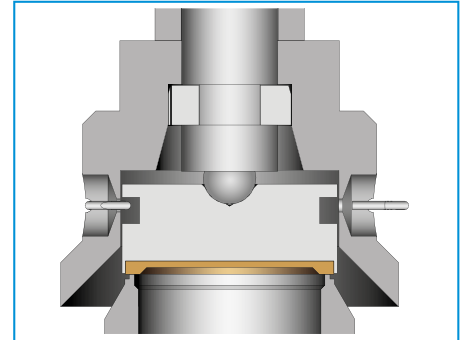

.11 Disc with soft seal for particularly high tightness

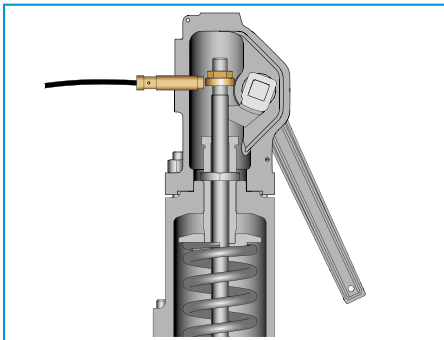

.14a Lift indication with inductive proximity switch in the cap. If the safety valve disc lifts by 1 mm minimum, the proximity switch will change its status and switch.

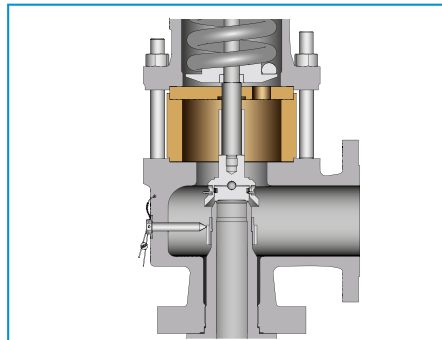

.15 Bonnet insulation spacer for protecting the spring against high and low temperatures

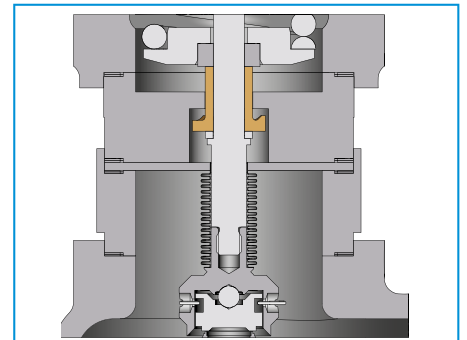

.17 Balancing piston balances the back pressure when bellows fails

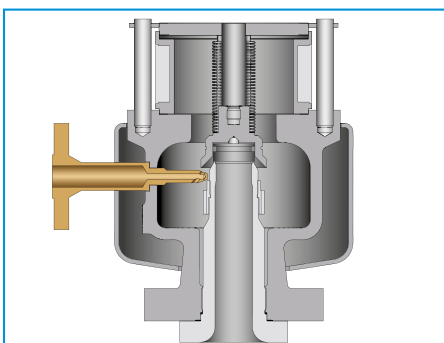

.32 Purge connection for constant cleaning of the safety valve seat and hence protecting it from conglutination

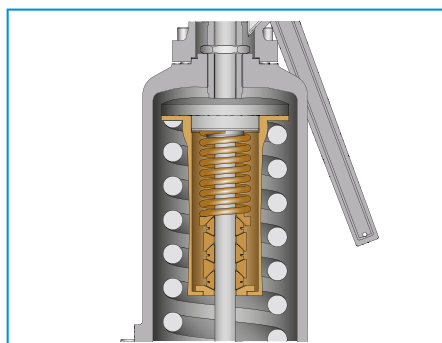

.38 Vibration damper for avoiding valve oscillation in case of unfavourable installation conditions

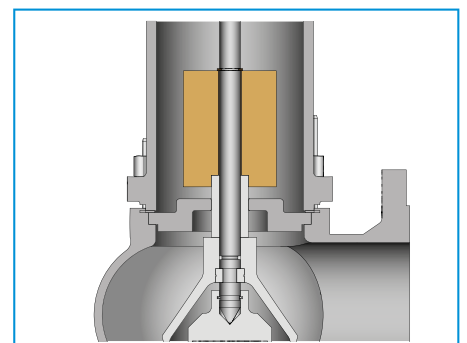

.57 Weight load for operation with very low set pressure

IMI Bopp & Reuther

Bopp & Reuther Sicherheits-
und Regelarmaturen GmbH
Carl-Reuther-Straße 1
68305 Mannheim
Deutschland

Tel: +49 (0)621 76220-100
Fax: +49 (0)621 76220-120

www.imi-critical.com
imibur.sales@imi-critical.com

IMI Critical Engineering

Lakeside, Solihull Parkway
Birmingham Business Park
Birmingham B37 7XZ
United Kingdom

Tel: +44 (0)121 717 3700
Fax: +44 (0)121 717 3701

www.imi-critical.com