

ELR-HD-4-QC
 END-OF-LINE FIBRERGLASS NEMA-4X
 ENCLOSURE W/TEST SWITCH AND COMPRESSION
 TERMINALS (4.7K RESISTOR)
 HEAVY DUTY ENCLOSURE
 DATA SHEET 9279
 1-14-2016

The illustration below depicts a typical wiring dressing of an ELR-HD-4-QC End-of-Line Resistor in a Class B detection circuit of a fire alarm system using Protectowire as the detector. This ELR unit is furnished with quick connect terminals which makes it possible to fasten the detector directly to the terminals. All bends in the Protectowire should have a radius of at least 2-1/2". For further information on detector splicing see diagram provided with splicing sleeves and in installation guide for Protectowire.

This End-of-Line Resistor is furnished with a Test Button. When the button is pressed the detection circuit to which it is connected will be placed in an alarm condition.

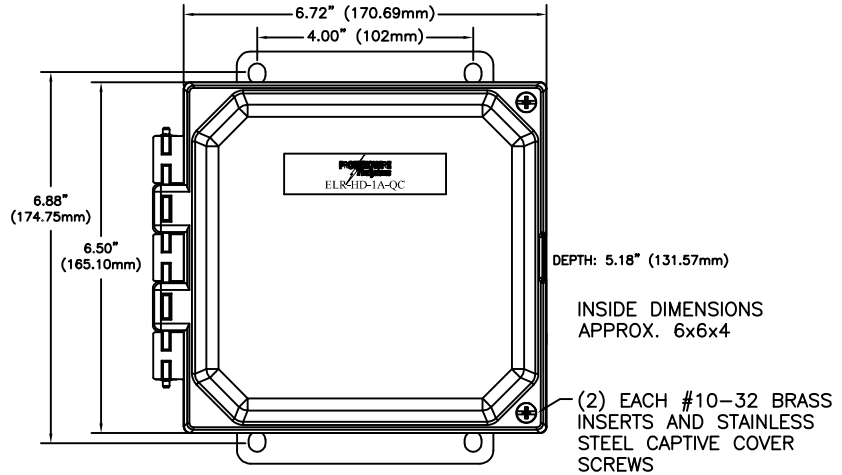

MOUNTING PANEL DETAIL
 4.81" x 4.81"
 (122.24mm) x (122.24mm)
 MOUNTED INSIDE OF CABINET

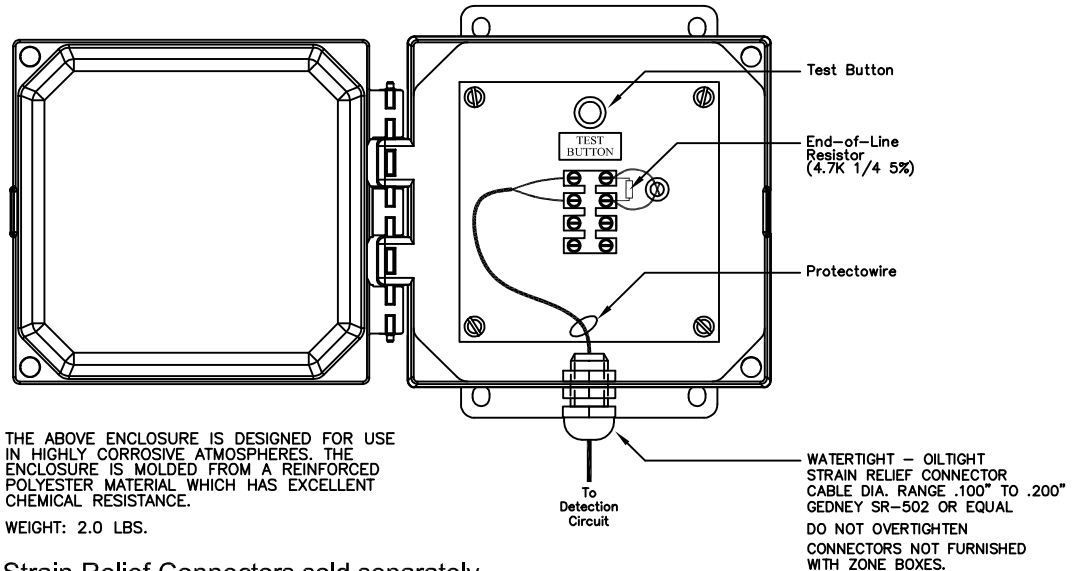

THE ABOVE ENCLOSURE IS DESIGNED FOR USE IN HIGHLY CORROSIVE ATMOSPHERES. THE ENCLOSURE IS MOLDED FROM A REINFORCED POLYESTER MATERIAL WHICH HAS EXCELLENT CHEMICAL RESISTANCE.
 WEIGHT: 2.0 LBS.

SR-502 Series Strain Relief Connectors sold separately

INSTALL IN ACCESSIBLE LOCATION PREFERABLY NOT MORE THAN SIX FEET ABOVE THE FLOOR.