

# B

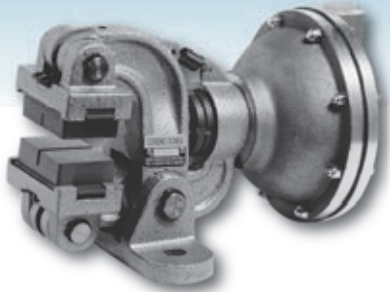

**MONTAGESCHEMA**  
Mounting positions

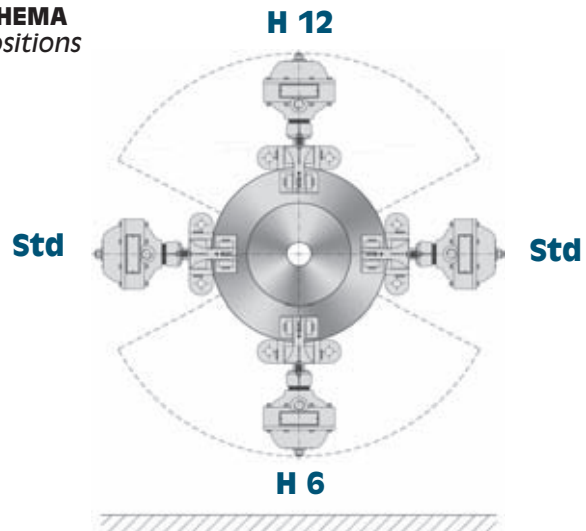

**Ausführung Doppelschuh**  
Double pad version

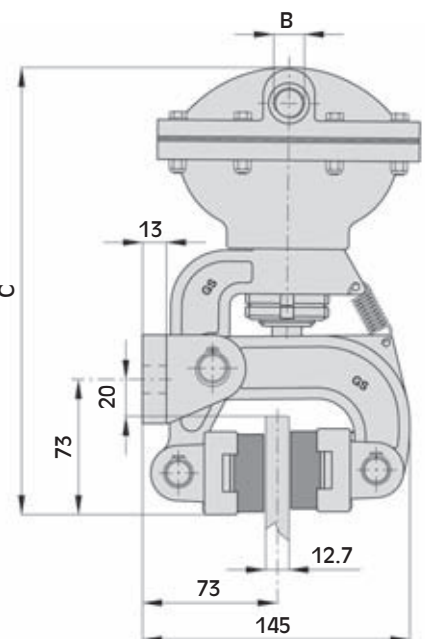
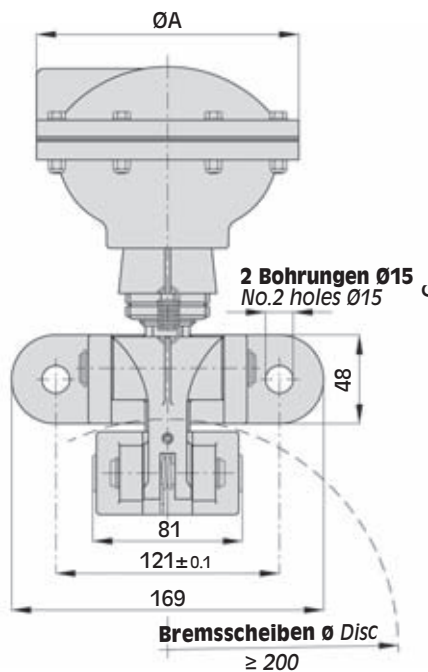
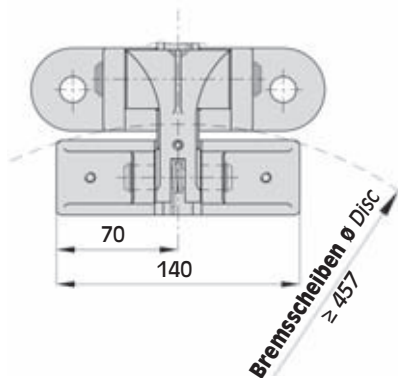

## ABMESSUNGEN/DIMENSIONS

TYP SIZE	Teil-Nr Product Number						ØA	B	C	Luftvolumen Air Volume dm <sup>3</sup>	Gewicht Weight kg
	Std	Std S.U.	H6	H6 S.U.	H12	H12 S.U.					
<b>B05</b>	A2014	A2015	A2348	A2349	A2354	A2355	74	1/4" Anschluss	210.5	0.025	5.3
<b>B1</b>	A2020	A2021	A2038	A2039	A2056	A2057	116	1/4" Anschluss	221	0.1	5.5
<b>B2</b>	A2026	A2027	A2044	A2045	A2062	A2063	142	3/8" Anschluss	243	0.2	6.3
	S.P. = Standard / Standard Production										
	S.U. = Ausführung mit Belag-Verschleissindikator / With Wear Indicator										

**Warnung:** Das anfängliche Bremsmoment neuer Bremsen/Bremsbeläge kann um 30-50% zu den Katalogwerten verringert sein, bis Bremsbeläge u. -scheiben eingelaufen sind!  
**Warning:** The initial torque on new units can be 30% to 50% less than the catalogue value until the friction facing and friction disc are lapped or worn in.

## Techn. Daten

Bremskraft F:

<b>B05</b>	670 N bei 6 bar
<b>B1</b>	1800 N bei 6 bar
<b>B2</b>	3550 N bei 6 bar

dyn. Bremsmoment:  
 $= F \cdot (\text{Scheibenradius(m)} - 0.032) = \text{Nm}$

Max. Belagverschleiss: 14 mm

Bremsbelagsdicke (neu): 16 mm

Dauerwärmeleistung: Qc: 1.7 kW

Dauerwärmeleistung:  
 Ausführung mit Doppelschuh Qc: 2.7 kW

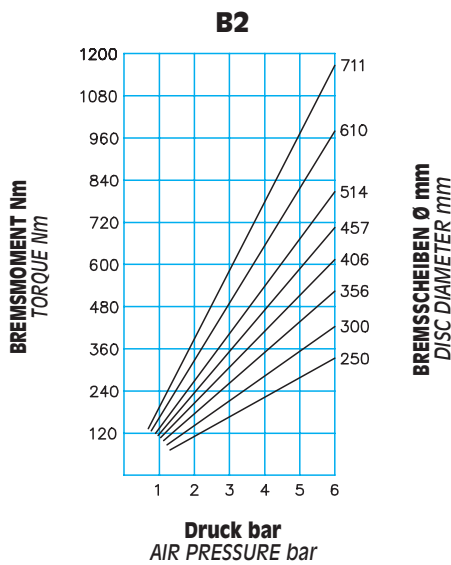
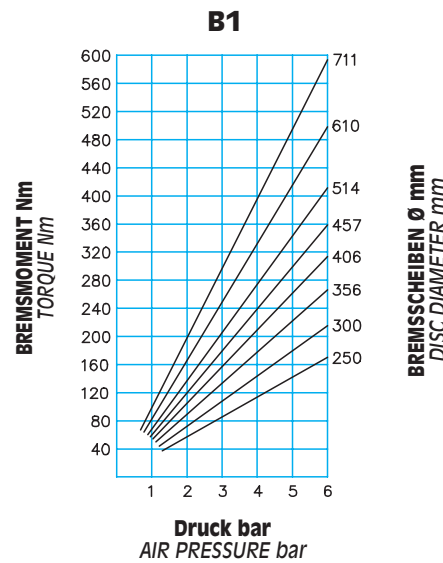
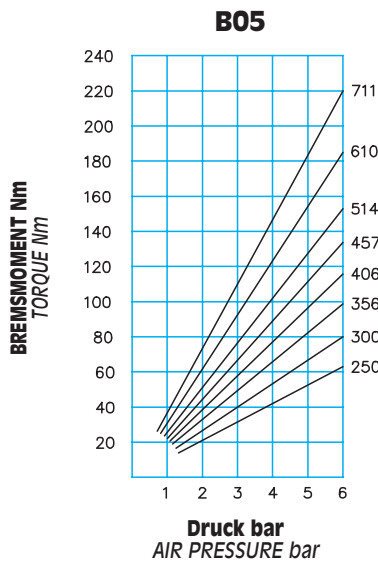

## Technical data

Braking force F:

<b>B05</b>	670 N at 6 bar
<b>B1</b>	1800 N at 6 bar
<b>B2</b>	3550 N at 6 bar

Dynamic torque  
 $= F \cdot (\text{disc radius in m} - 0.032) = \text{Nm}$

Max total wear: 14 mm

Thickness of new lining: 16 mm

Continuous thermal capacity  
 Qc: 1.7 kW

Continuous thermal capacity  
 for double pad version  
 Qc: 2.7 kW

## DIAGRAMM/CHART

**Therm. Kapazität für Notstop**

Thermal capacity for emergency stop

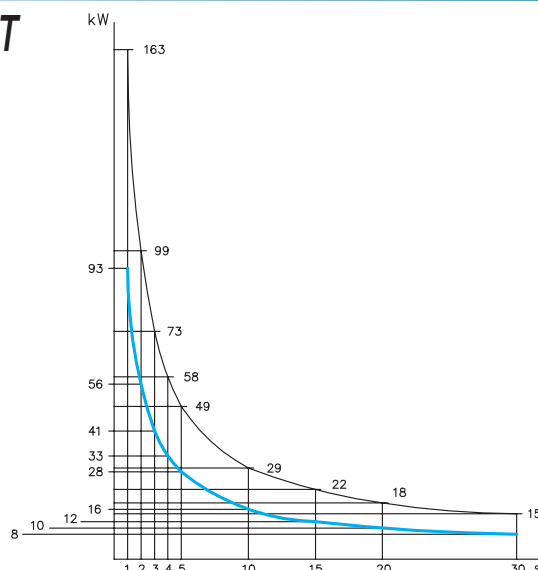

Doppelschuh Double pad  
 Standard Standard pad